

LSP50U

Unità di centraggio fori e bloccaggio pneumatica



L	S	P	5	0	U	U	3	1	0	0	0	0
1	2	3	4	5	6	7	8	9				

1 Serie LS = Unità di centraggio fori e bloccaggio	2 Versione P = Pneumatica standard	3 Taglia 50 = Ø 50 mm
4 Modello U = Ingombro orizzontale	5 Sensore di posizione U = Sensore elettronico con connettore M12 orientabile N = Senza sensore (con piastra di chiusura)	6 Diametro perno 1 ≤ Ø 19 mm 2 = Ø 20 mm 3 = Ø 25 mm 4 = Ø 30 mm 5 = Ø 35 mm 6 = Ø 40 mm
7 Presenza perno di centraggio 0 = Perno di centraggio non incluso 1 = Perno di centraggio incluso	8 Quota lavoro 0 = Standard, diverse quote a richiesta	9 Numerazione progressiva Numerazione progressiva per prodotto speciale a cura dell'Ufficio Commerciale

UNIVERSAL Pneumatic pin clamp

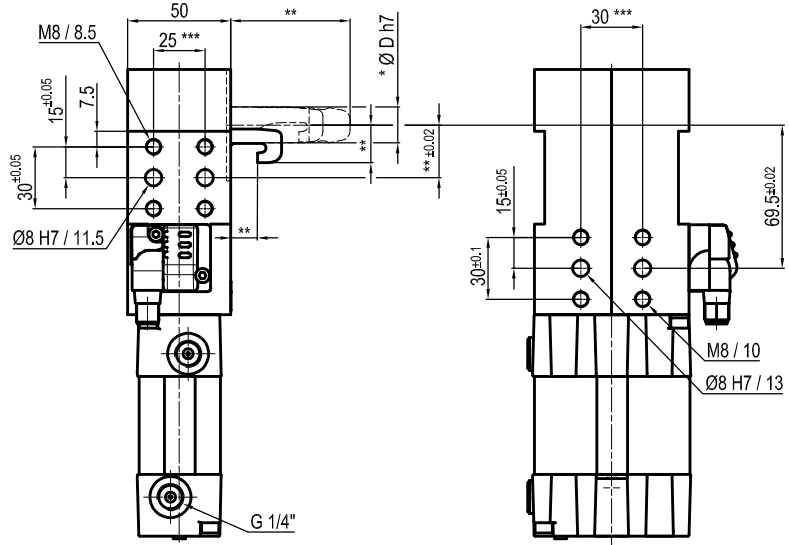
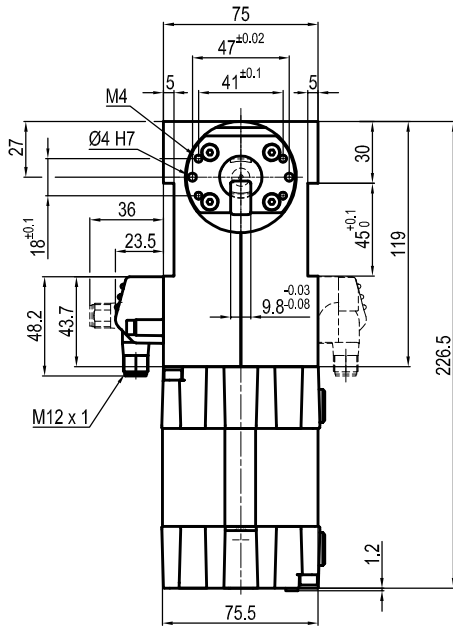

*	ØD
1	≤19
2	20
3	25
4	30
5	35
6	40

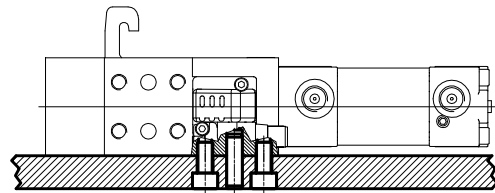
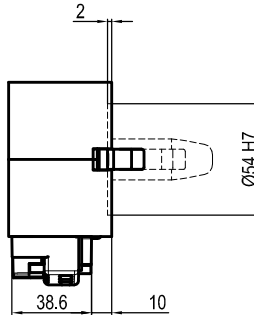

** : Missing dimension to be defined according to customer specifications

Bore Ø	Clamping force	Weight
50 mm	400 Kg	2.2 Kg

Min./Max. operating pressure: **0,4 / 0,6 MPa**

Operating temperature: **5° + 45° C**

Electronic sensor with M12 swivel connector that can be orientated at 0° or 90°

Supply voltage: 10+30 Vdc

IP code: **IP 54**

Pneumatic ports on both sides

*** : TOLERANCE BETWEEN DOWEL HOLES ± 0.02, TO SCREW HOLES ± 0.1
THE SENSOR CAN BE MOUNTED ON EITHER RIGHT OR LEFT SIDE

subject to technical modifications without notice

UNIVERSAL Pneumatic pin clamp

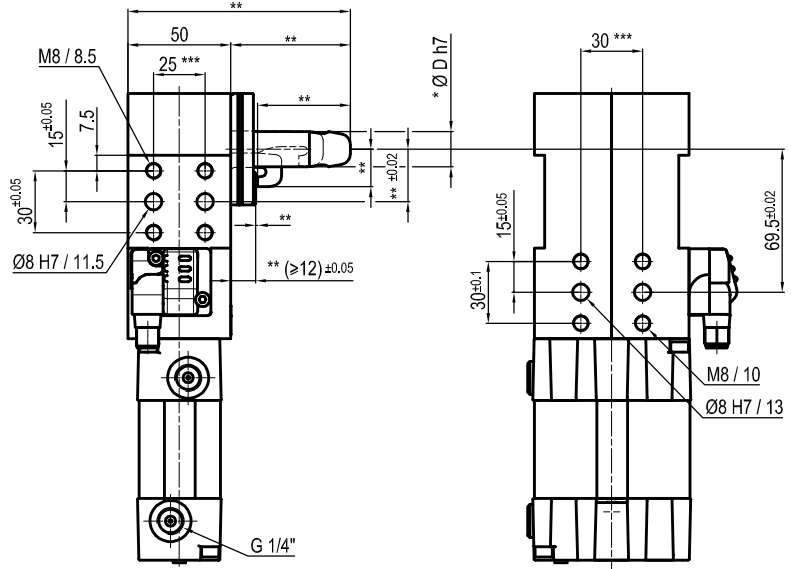
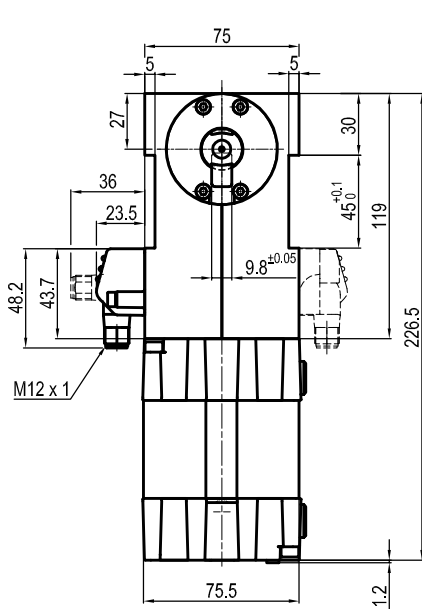

*	ØD
1	≤19
2	20
3	25
4	30
5	35
6	40

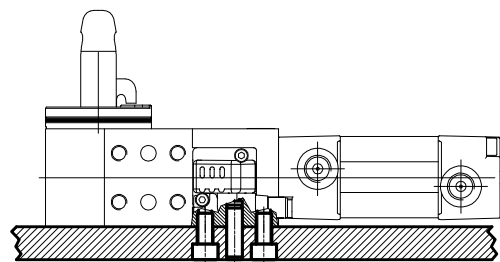
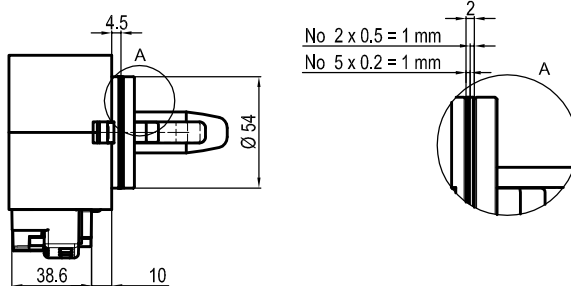

** : Missing dimension to be defined according to customer specifications

Bore Ø	Clamping force	Weight
50 mm	400 Kg	2.2 Kg

Min./Max. operating pressure: **0,4 / 0,6 MPa**

Operating temperature: **5° + 45° C**

Electronic sensor with M12 swivel connector that can be orientated at 0° or 90°

Supply voltage: 10+30 Vdc

IP code: **IP 54**

Pneumatic ports on both sides

*** : TOLERANCE BETWEEN DOWEL HOLES ± 0.02, TO SCREW HOLES ± 0.1
THE SENSOR CAN BE MOUNTED ON EITHER RIGHT OR LEFT SIDE

subject to technical modifications without notice