

LCR50

Unità di centraggio pneumatica, testate compatte
singola asta



L	C	R	5	0	0	5	0	E	A	E	R
1	2	3	4				5	6	7	8	

1 Serie	2 Versione	3 Taglia
----------------	-------------------	-----------------

LC = Unità di centraggio

R = Pneumatica, testate compatte,
singola asta

50 = Ø 50 mm

4 Corse	5 Sensore di posizione	6 Terminale asta
----------------	-------------------------------	-------------------------

015 = 15 mm
025 = 25 mm
040 = 40 mm
050 = 50 mm
060 = 60 mm

N = Senza sensore
(con piastra di chiusura)
E = Sensore elettronico con connettore
M12 orientabile

A = Asta per centraggi dislocati
B = Asta con impronta a chiave
C = Asta con impronta a chiave a croce,
Ø interno 16 mm
D = Asta per centraggi dislocati con fori spina
maggiorati
E = Asta con impronta chiave a croce,
Ø interno 10 mm
F = Asta con sede fissaggio laterale
H = Asta con terminale piatto, Ø interno 10 mm
I = Asta con terminale piatto, Ø interno 12 mm
L = Asta con foro Ø 12 compatibile con
CNOMO LCG
M = Asta con foro Ø 20 compatibile con
CNOMO LCG

7 Orientamento asta	8 Raschiastelo
----------------------------	-----------------------

E = Est, standard



O = Ovest



N = Nord



S = Sud



R = Raschiastelo metallico

■ Solo con terminale asta A o D

UNIVERSAL Pneumatic retractable locating pin unit

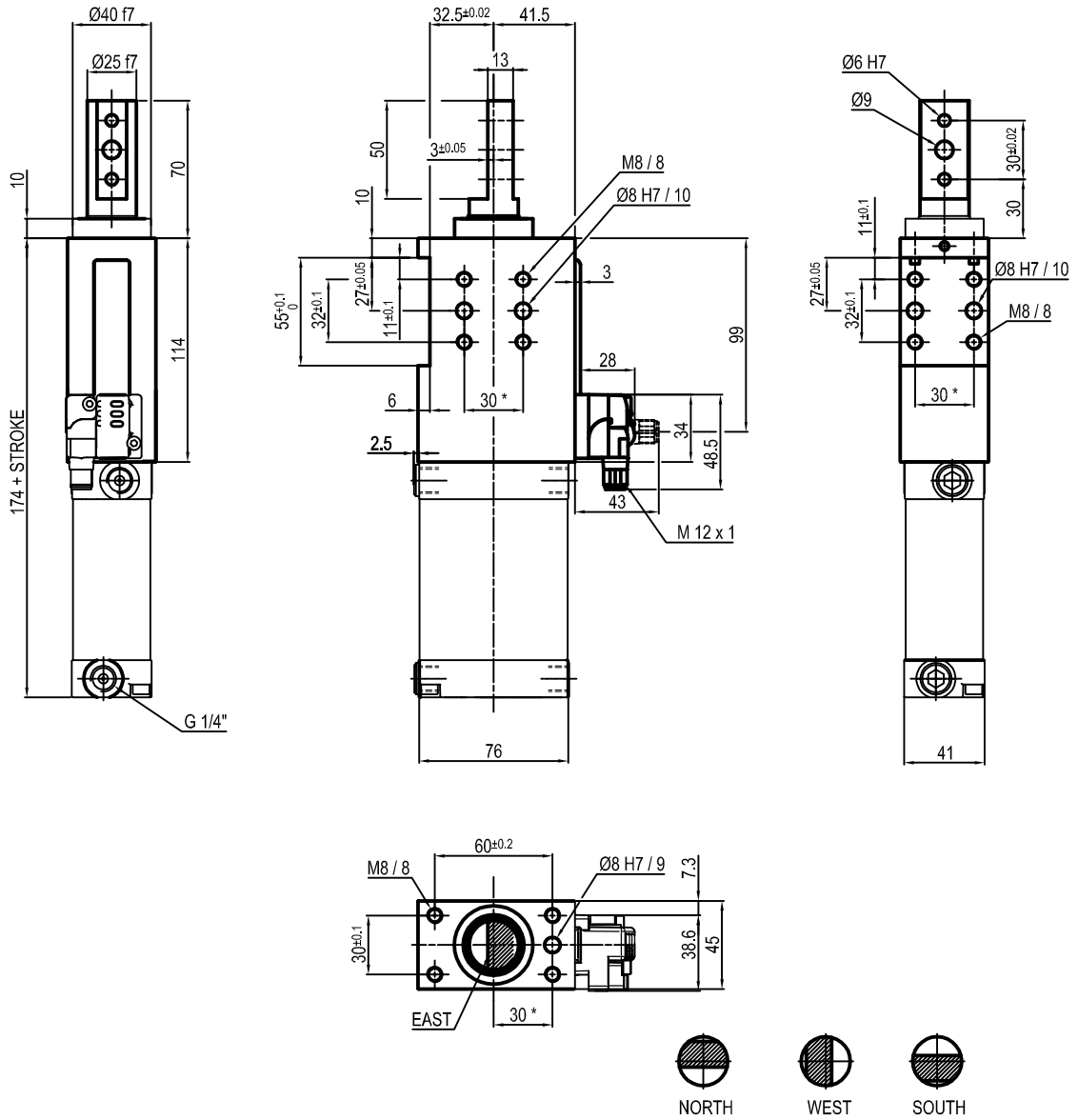

Bore Ø	Max. torque	Max. deflection moment	Weight
50 mm	6 Nm ±0.06°	7.5 Nm ±0.03°	2.3 Kg

Min./max. operating pressure: **0,4 / 0,6 MPa**
 Operating temperature: **5° + 45° C**
 Strokes in mm.: **15 - 25 - 40 - 50 - 60**
 Electronic sensor with M12 swivel connector that can be orientated at 0° or 90°
 Supply voltage: 10+30 Vdc
 IP code: **IP 65**
 Pneumatic ports on both sides

* : TOLERANCE BETWEEN DOWEL HOLES ± 0.02, TO SCREW HOLES ± 0.1

Subject to technical modification without notice.

UNIVERSAL Pneumatic retractable locating pin unit

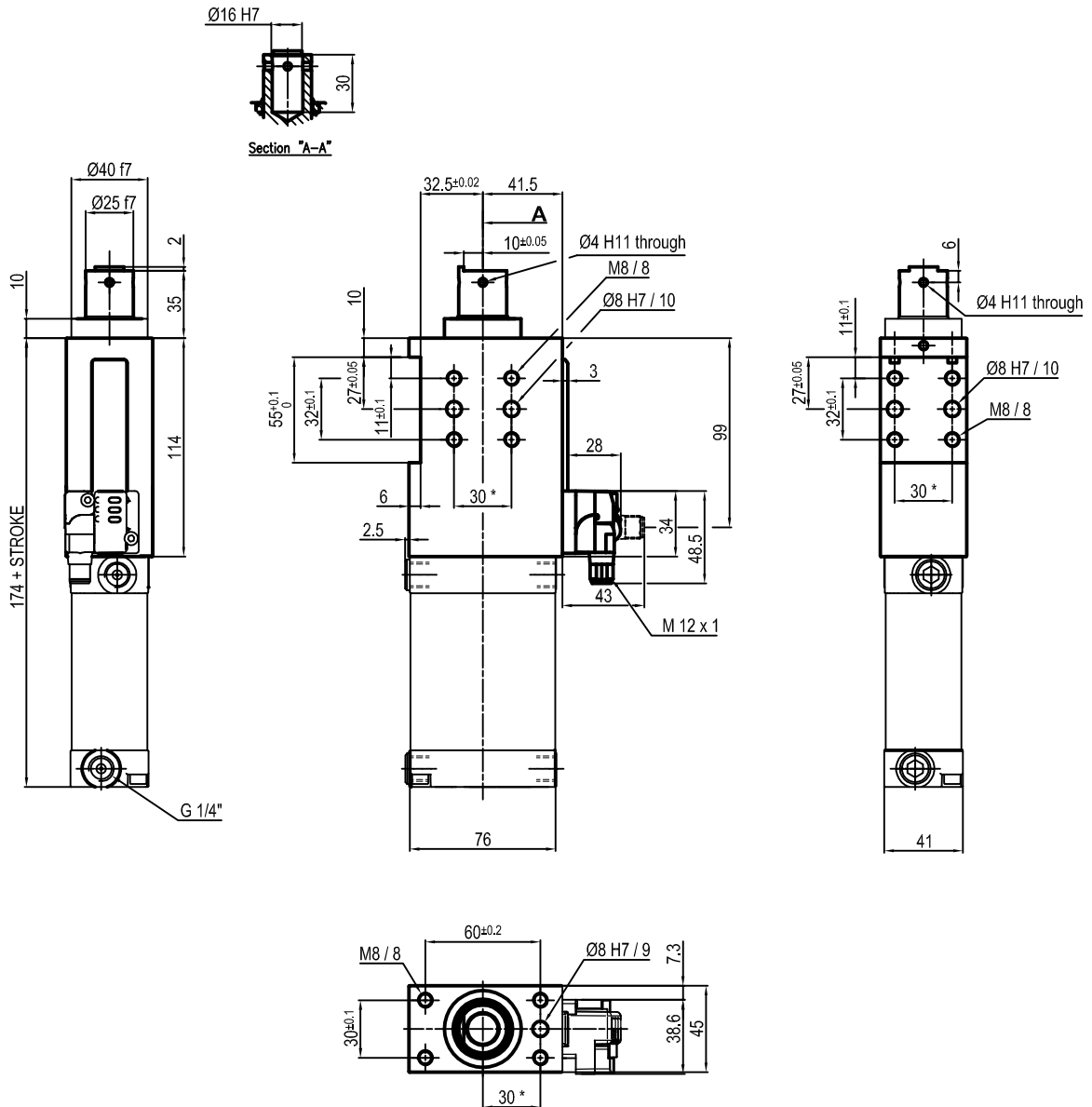

Bore Ø	Max. torque	Max. deflection moment	Weight
50 mm	6 Nm ±0.06°	7.5 Nm ±0.03	2.3 Kg

Min./max. operating pressure: **0,4 / 0,6 MPa**
 Operating temperature: **5° + 45° C**
 Strokes in mm.: **15 - 25 - 40 - 50 - 60**
 Electronic sensor with M12 swivel connector that can be orientated at 0° or 90°
 Supply voltage: 10+30 Vdc
 IP code: **IP 65**
 Pneumatic ports on both sides

* : TOLERANCE BETWEEN DOWEL HOLES ± 0.02, TO SCREW HOLES ± 0.1

Subject to technical modification without notice.

UNIVERSAL Pneumatic retractable locating pin unit

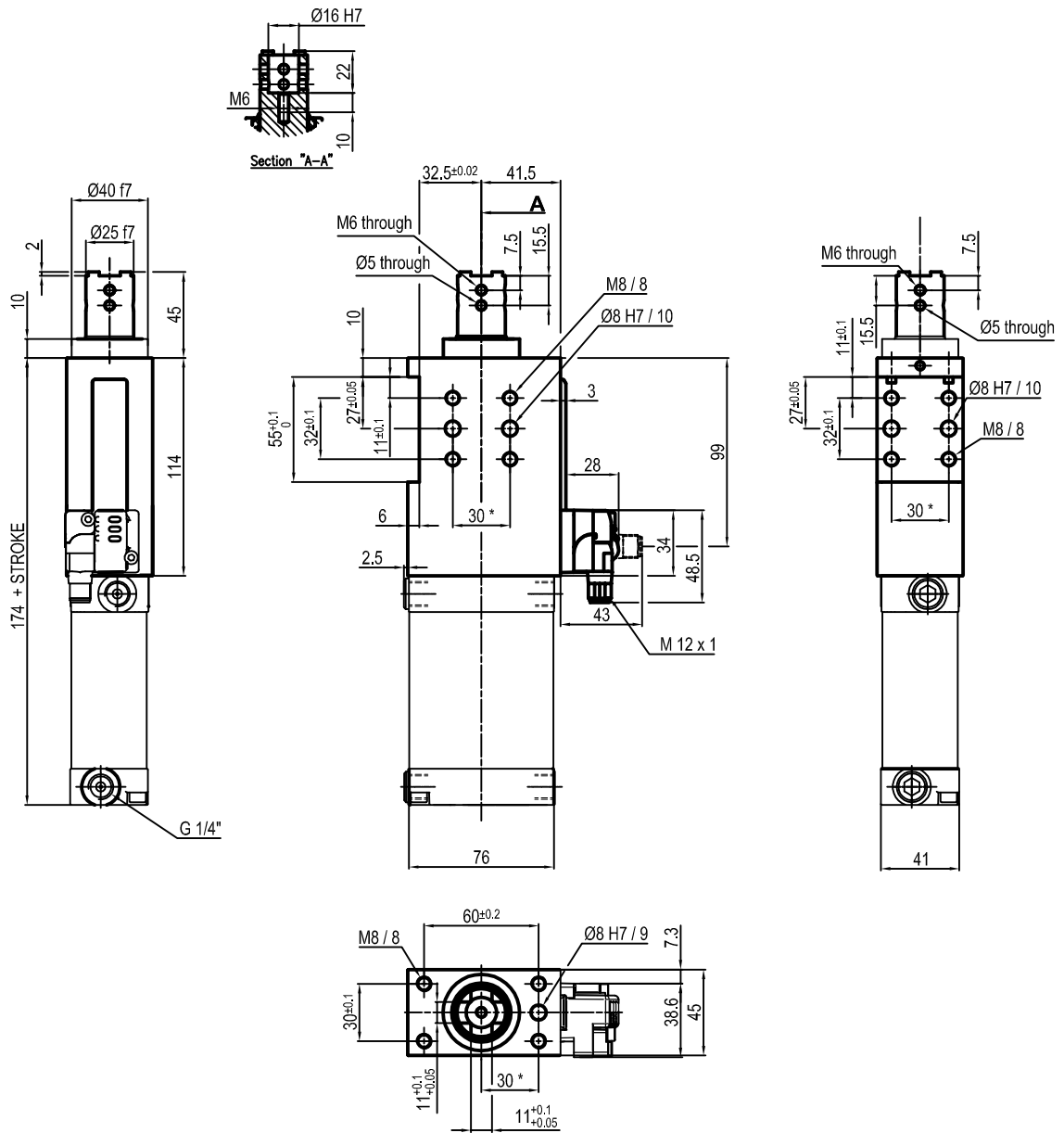

Bore Ø	Max. torque	Max. deflection moment	Weight
50 mm	6 Nm ±0.06°	7.5 Nm ±0.03°	2.3 Kg

Min./max. operating pressure: **0,4 / 0,6 MPa**
 Operating temperature: **5° + 45° C**
 Strokes in mm.: **15 - 25 - 40 - 50 - 60**
 Electronic sensor with M12 swivel connector that can be orientated at 0° or 90°
 Supply voltage: 10+30 Vdc
 IP code: **IP 65**
 Pneumatic ports on both sides

* : TOLERANCE BETWEEN DOWEL HOLES ± 0.02, TO SCREW HOLES ± 0.1

Subject to technical modification without notice.

UNIVERSAL Pneumatic retractable locating pin unit

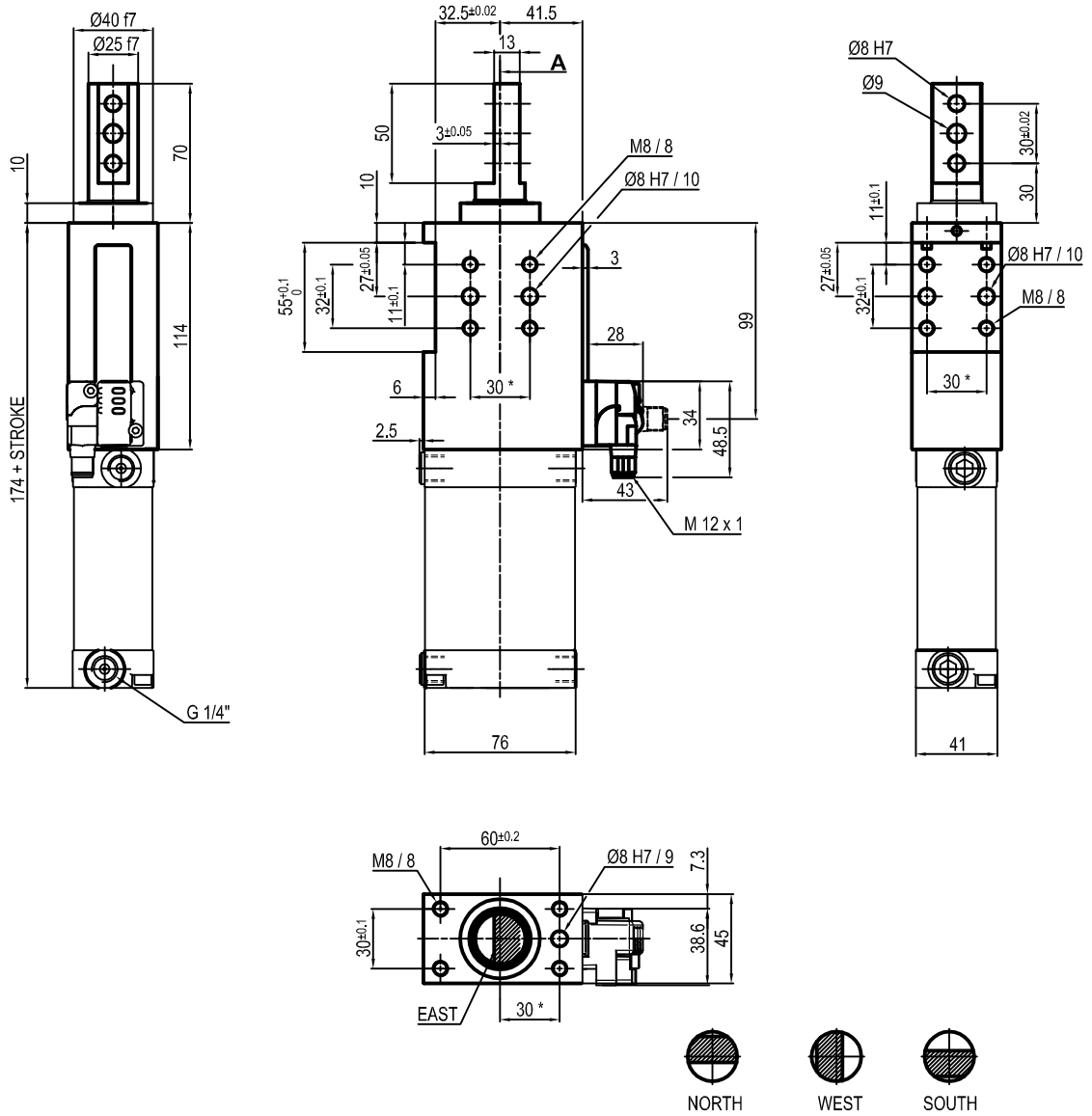

Bore Ø	Max. torque	Max. deflection moment	Weight
50 mm	6 Nm ±0.06°	7.5 Nm ±0.03°	2.3 Kg

Min./max. operating pressure: **0,4 / 0,6 MPa**
 Operating temperature: **5° + 45° C**
 Strokes in mm.: **15 - 25 - 40 - 50 - 60**
 Electronic sensor with M12 swivel connector that can be orientated at 0° or 90°
 Supply voltage: 10+30 Vdc
 IP code: **IP 65**
 Pneumatic ports on both sides

* : TOLERANCE BETWEEN DOWEL HOLES ± 0.02, TO SCREW HOLES ± 0.1

Subject to technical modification without notice.

UNIVERSAL Pneumatic retractable locating pin unit rod inner $\varnothing=10$ mm

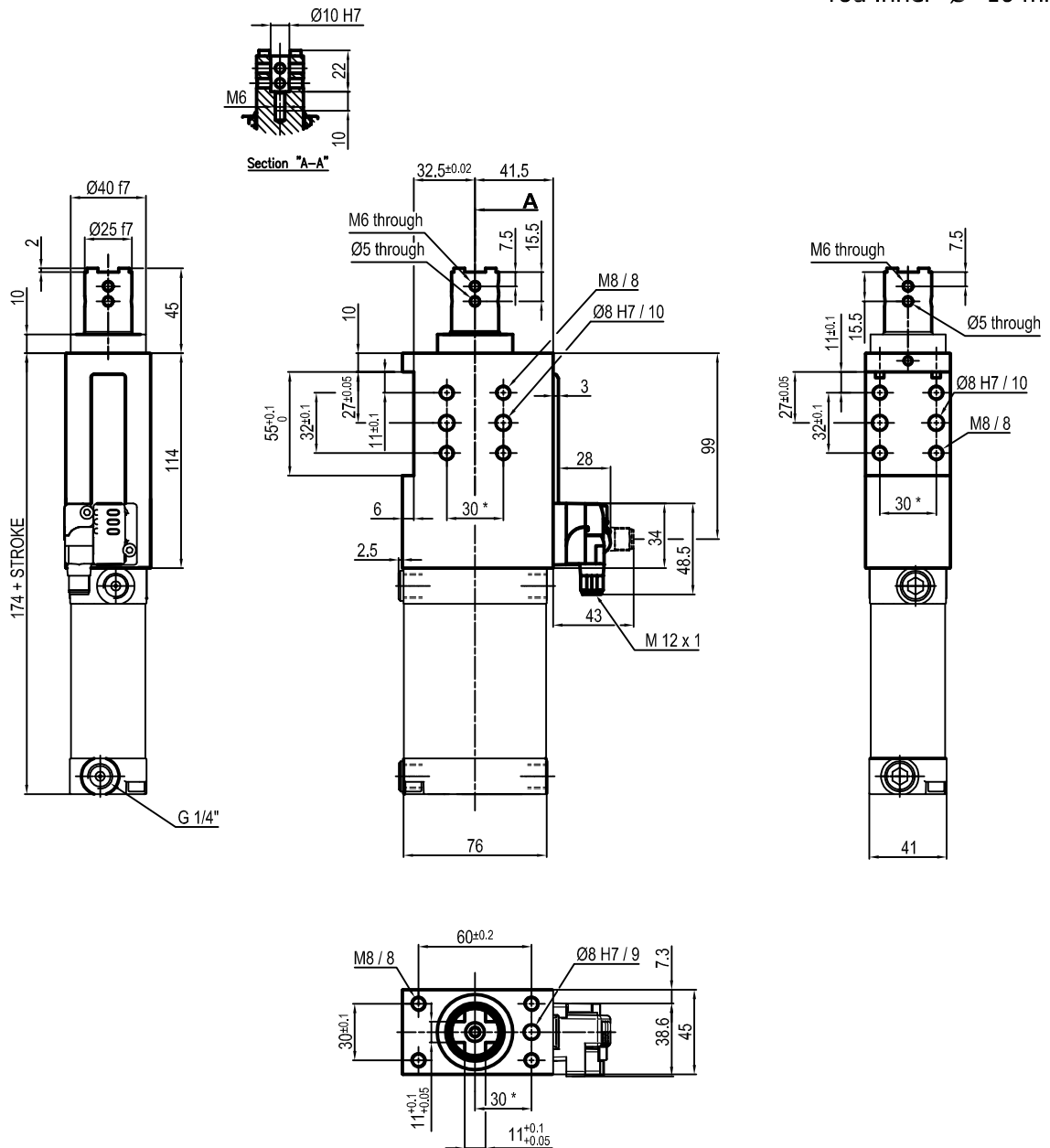

Bore \varnothing	Max. torque	Max. deflection moment	Weight
50 mm	6 Nm $\pm 0.06^\circ$	7.5 Nm $\pm 0.03^\circ$	2.3 Kg

Min./max. operating pressure: **0,4 / 0,6 MPa**
 Operating temperature: **5° + 45° C**
 Strokes in mm.: **15 - 25 - 40 - 50 - 60**
 Electronic sensor with M12 swivel connector that can be orientated at 0° or 90°
 Supply voltage: 10+30 Vdc
 IP code: **IP 65**
 Pneumatic ports on both sides

* : TOLERANCE BETWEEN DOWEL HOLES ± 0.02 , TO SCREW HOLES ± 0.1

Subject to technical modification without notice.

UNIVERSAL Pneumatic retractable locating pin unit

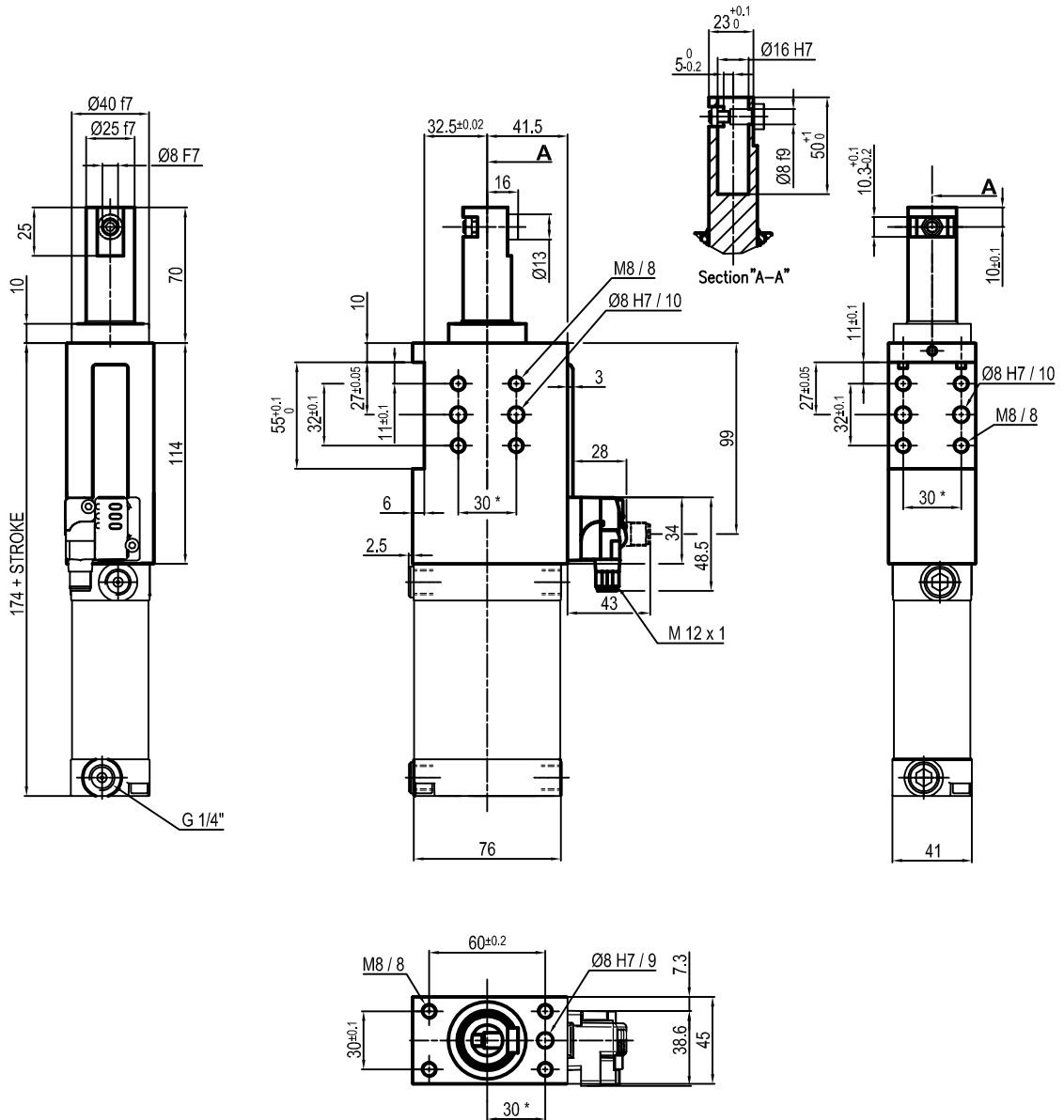

Bore Ø	Max. torque	Max. deflection moment	Weight
50 mm	6 Nm ±0.06°	7.5 Nm ±0.03°	2.3 Kg

Min./max. operating pressure: **0,4 / 0,6 MPa**
 Operating temperature: **5° + 45° C**
 Strokes in mm.: **15 - 20 - 25 - 40 - 50 - 60**
 Electronic sensor with M12 swivel connector that can be orientated at 0° or 90°
 Supply voltage: 10+30 V DC
 IP code: **IP 65**
 Pneumatic ports on both sides

* : TOLERANCE BETWEEN DOWEL HOLES ± 0.02, TO SCREW HOLES ± 0.1

Subject to technical modification without notice.

UNIVERSAL Pneumatic retractable locating pin unit rod inner Ø=10 mm

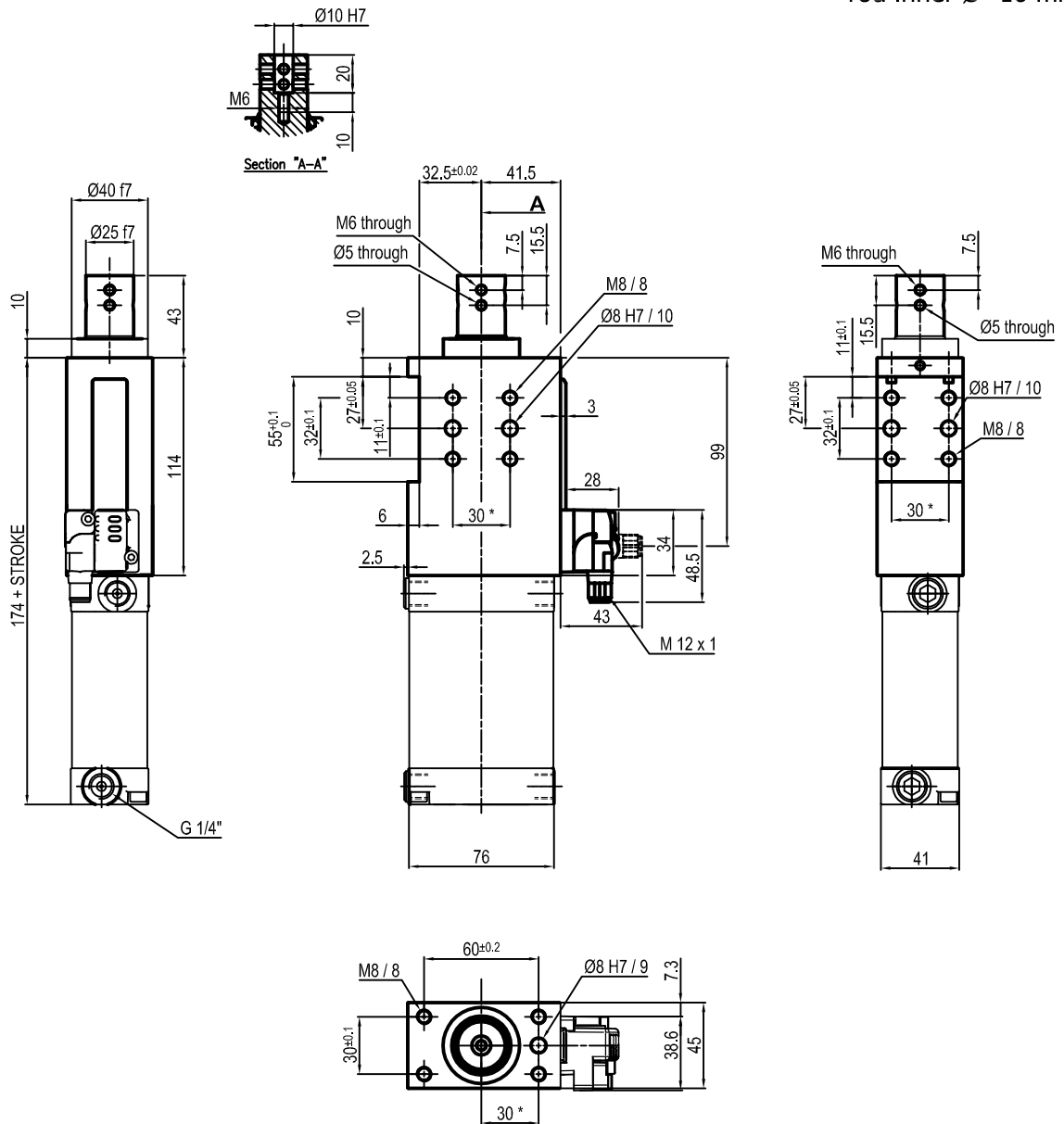

Bore Ø	Max. torque	Max. deflection moment	Weight
50 mm	6 Nm ±0.06°	7.5 Nm ±0.03°	2.3 Kg

Min./max. operating pressure: **0,4 / 0,6 MPa**
 Operating temperature: **5° + 45° C**
 Strokes in mm.: **15 - 25 - 40 - 50 - 60**
 Electronic sensor with M12 swivel connector that can be orientated at 0° or 90°
 Supply voltage: 10+30 Vdc
 IP code: **IP 65**
 Pneumatic ports on both sides

* : TOLERANCE BETWEEN DOWEL HOLES ± 0.02, TO SCREW HOLES ± 0.1

Subject to technical modification without notice.

UNIVERSAL Pneumatic retractable locating pin unit rod inner Ø=12 mm

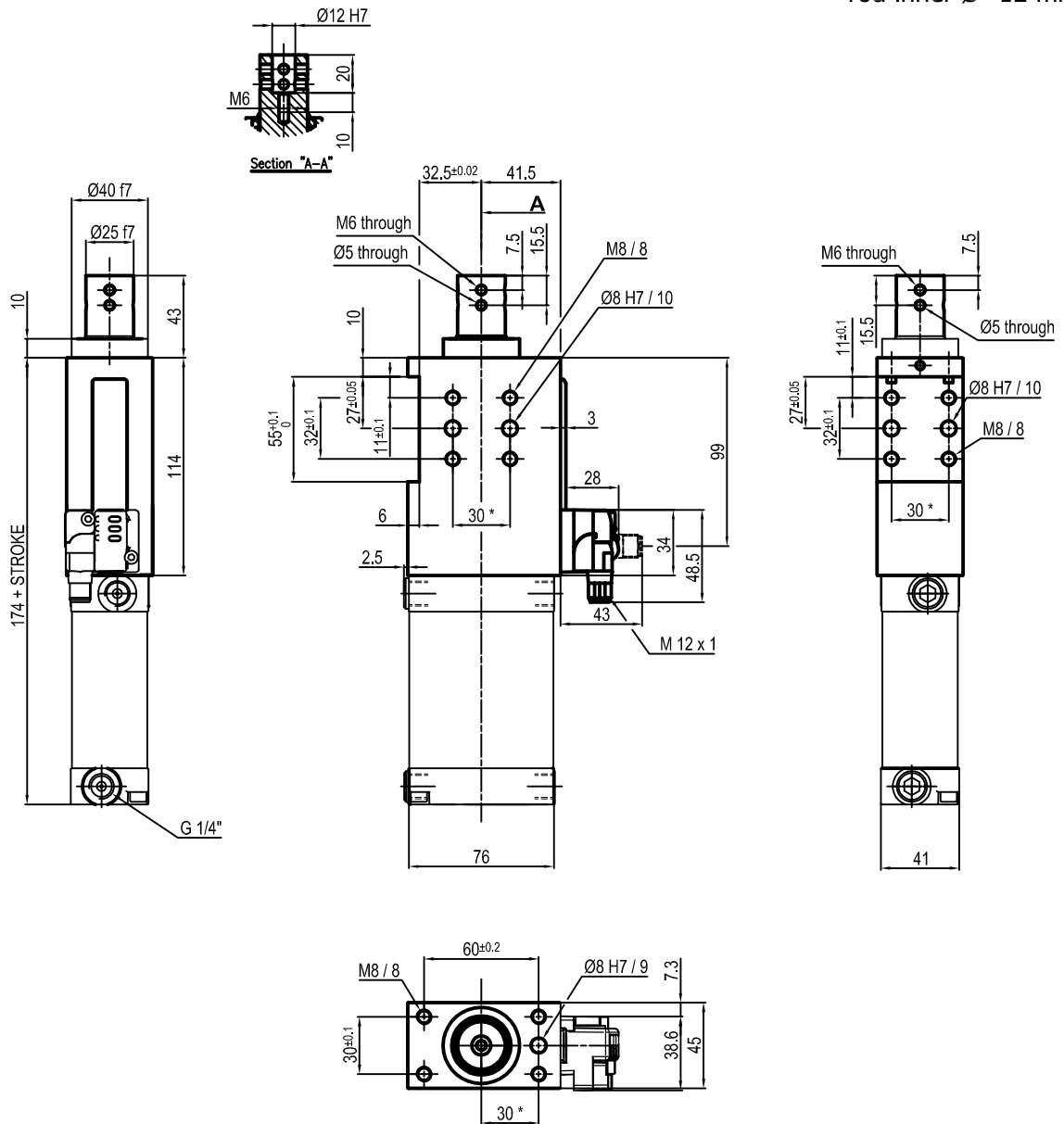

Bore Ø	Max. torque	Max. deflection moment	Weight
50 mm	6 Nm ±0.06°	7.5 Nm ±0.03°	2.3 Kg

Min./max. operating pressure: **0,4 / 0,6 MPa**
 Operating temperature: **5° + 45° C**
 Strokes in mm.: **15 - 25 - 40 - 50 - 60**
 Electronic sensor with M12 swivel connector that can be orientated at 0° or 90°
 Supply voltage: 10+30 Vdc
 IP code: **IP 65**
 Pneumatic ports on both sides

* : TOLERANCE BETWEEN DOWEL HOLES ± 0.02, TO SCREW HOLES ± 0.1

Subject to technical modification without notice.

UNIVERSAL Pneumatic retractable locating pin unit

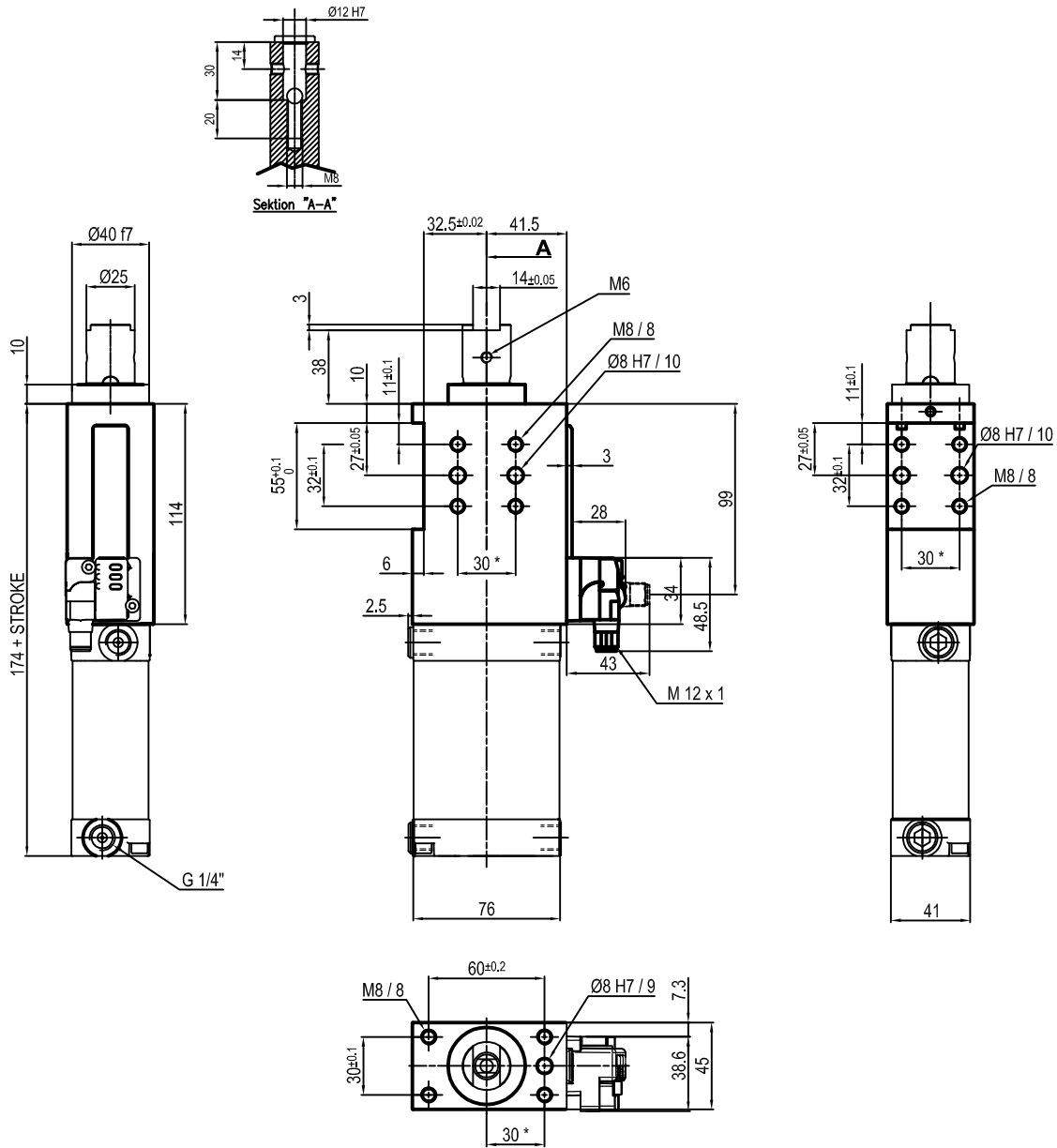

Bore Ø	Max. torque	Max. deflection moment	Weight
50 mm	6 Nm ±0.06°	7.5 Nm ±0.03°	2.3 Kg

Min./max. operating pressure: **0,4 / 0,6 MPa**
 Operating temperature: **5° + 45° C**
 Strokes in mm.: 25 - 50
 Electronic sensor with M12 swivel connector that can be orientated at 0° or 90°
 Supply voltage: 10+30 Vdc
 IP code: **IP 65**
 Pneumatic ports on both sides

* : TOLERANCE BETWEEN DOWEL HOLES ± 0.02, TO SCREW HOLES ± 0.1

Subject to technical modification without notice.

UNIVERSAL Pneumatic retractable locating pin unit

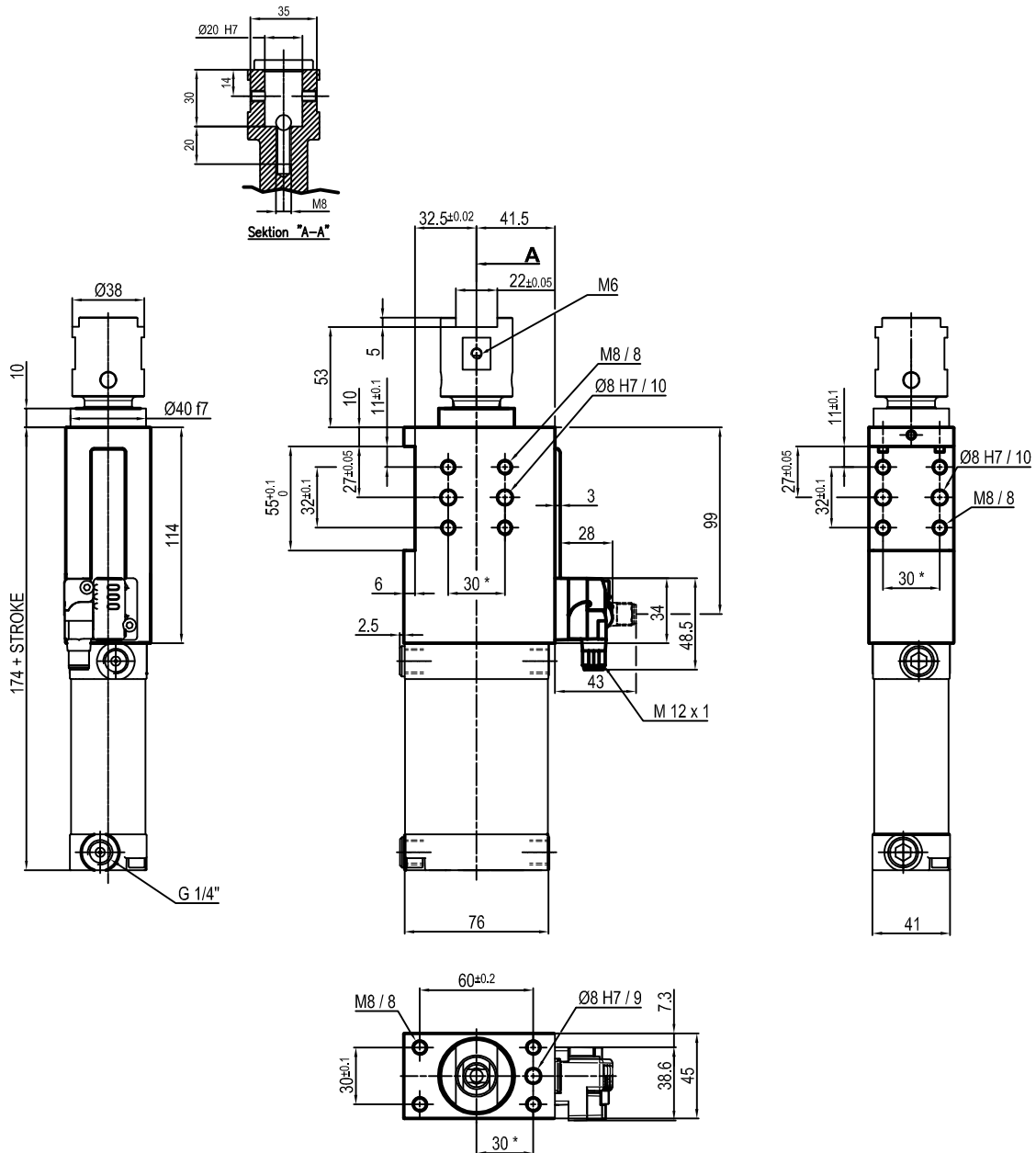

Bore Ø	Max. torque	Max. deflection moment	Weight
50 mm	6 Nm ±0.06°	7.5 Nm ±0.03°	2.3 Kg

Min./max. operating pressure: **0,4 / 0,6 MPa**
 Operating temperature: **5° + 45° C**
 Strokes in mm.: 25 - 50
 Electronic sensor with M12 swivel connector that can be orientated at 0° or 90°
 Supply voltage: 10+30 Vdc
 IP code: **IP 65**
 Pneumatic ports on both sides

* : TOLERANCE BETWEEN DOWEL HOLES ± 0.02, TO SCREW HOLES ± 0.1

Subject to technical modification without notice.