

UBT40

Unità di bloccaggio UNIVERSAL



U	B	T	4	0	N	N	E
1	2	3	4	5	6		

1 Serie

UB = Unità di bloccaggio UNIVERSAL con regolazione continua angolo d'apertura da: **0° a 135°**
L'angolo di apertura può variare a seconda della posizione e della tipologia del pressore

2 Versione

T = Pneumatica con leva manuale centrale

3 Taglia

40 = Ø 40 mm

4 Posizione pressore

V = 90° **O** = 180° **N** = Senza pressore

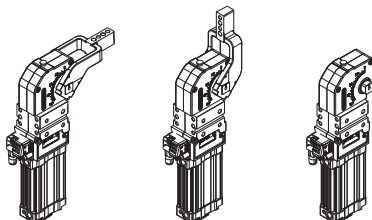

5 Tipo di pressore

C = Centrale, 15 mm offset (standard)
D = Destro, 15 mm offset (standard)
S = Sinistro, 15 mm offset (standard)
E = Centrale, 45 mm offset
F = Destro, 45 mm offset
L = Sinistro, 45 mm offset
N = Senza pressore
X = Centrale con fori maggiorati Ø 8 H7, 15 mm offset
Y = Destro con fori maggiorati Ø 8 H7, 15 mm offset
Z = Sinistro con fori maggiorati Ø 8 H7, 15 mm offset

6 Sensore di posizione

N = Senza sensore (con piastra di chiusura)
E = Sensore elettronico con connettore M12 orientabile
D = Sensore pneumatico

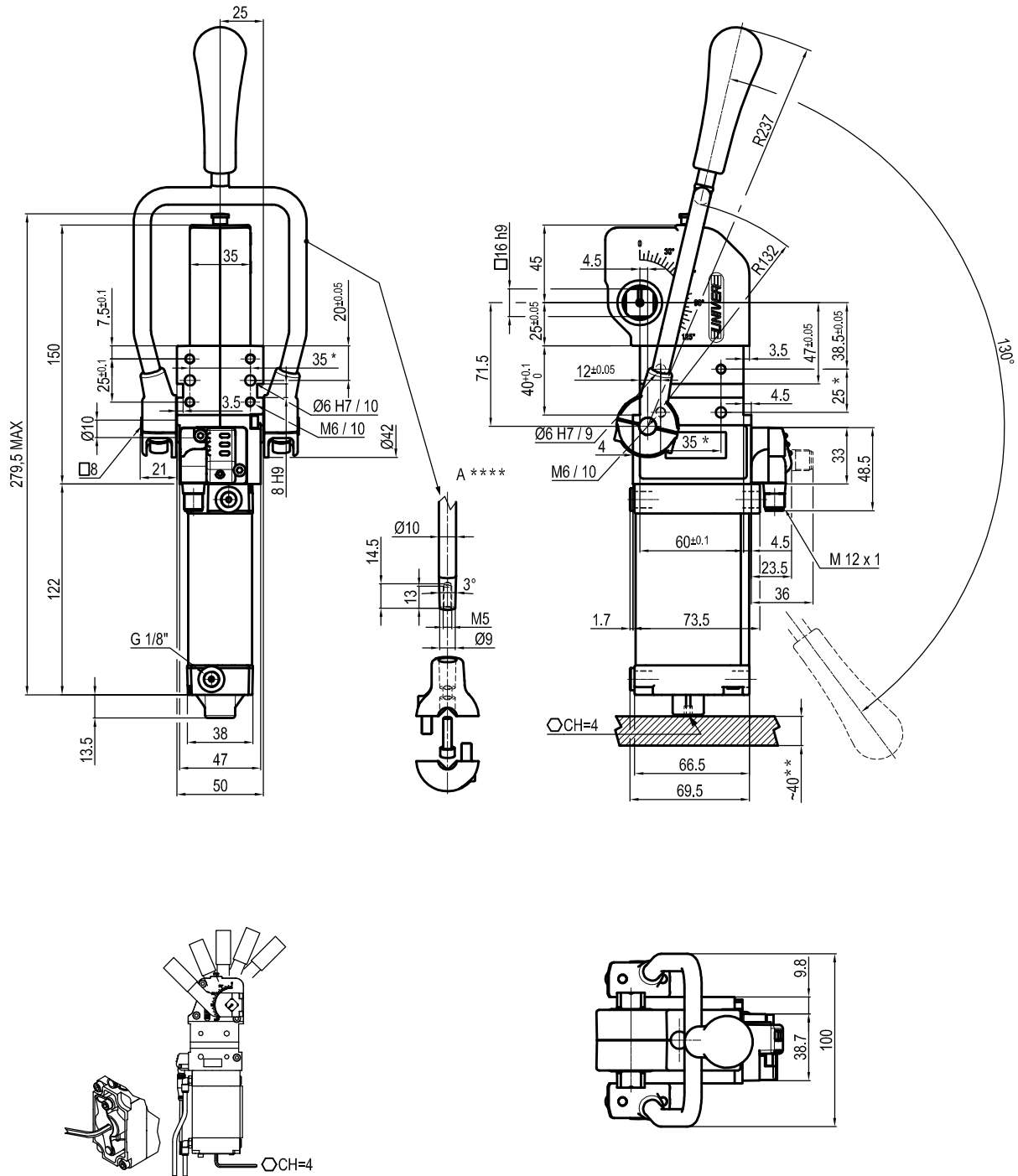

Bore Ø	Holding moment	Clamping moment (0.5 MPa)	Weight (Clamping arm not included)
40 mm	600 Nm	170 Nm	1.8 Kg

Min./Max. operating pressure: **0,4 / 0,6 MPa**

Operating temperature: **5° + 45° C**

Opening angle: **adjustable**

Without arm

Electronic sensor with M12 swivel connector that can be orientated at 0° or 90°

Supply voltage: 10÷30 Vdc

IP code: **IP 65**

Pneumatic ports on both sides

* : TOLERANCE BETWEEN DOWELS ± 0.02, TO SCREW HOLES ± 0.1

** : AREA TO ACCESS ANGLE ADJUSTMENT

Subject to technical modifications without notice

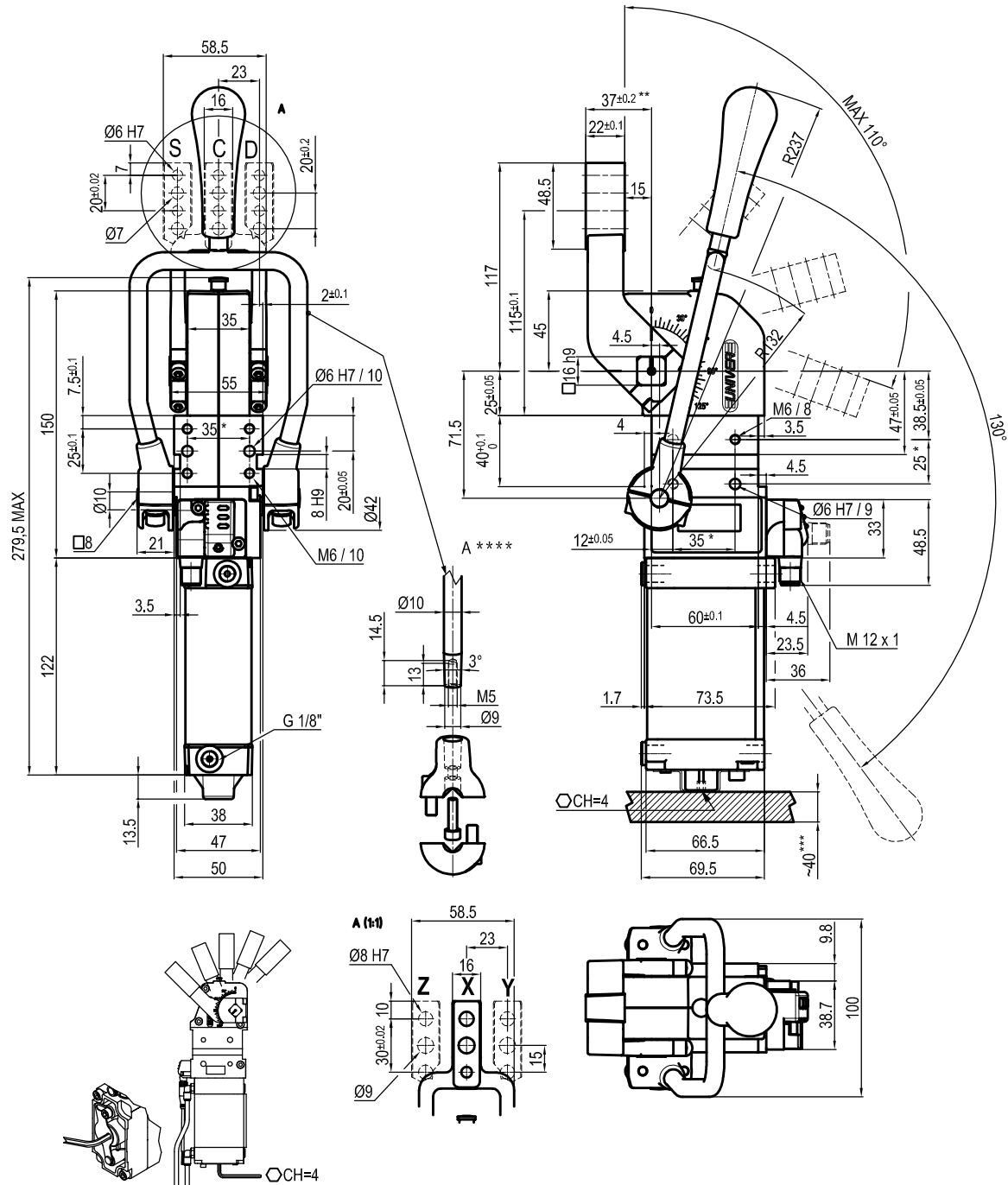

Bore Ø	Holding moment	Clamping moment (0.5 MPa)	Weight (Clamping arm not included)
40 mm	600 Nm	170 Nm	1.8 Kg

Min./Max. operating pressure: **0,4 / 0,6 MPa**
 Operating temperature: **5° + 45° C**
 Opening angle: **adjustable from 0° to 110°**
 Horizontal arm mount position
 Electronic sensor with M12 swivel connector that can be orientated at 0° or 90°
 Supply voltage: 10÷30 Vdc
 IP code: **IP 65**
 Pneumatic ports on both sides

* : TOLERANCE BETWEEN DOWELS ± 0.02, TO SCREW HOLES ± 0.1
 ** : TOLERANCE AT 80 mm FROM PIVOT POINT
 *** : AREA TO ACCESS ANGLE ADJUSTMENT

Subject to technical modification without notice.

UNIVERSAL Pneumatic clamp arm at 45 mm from pivot point

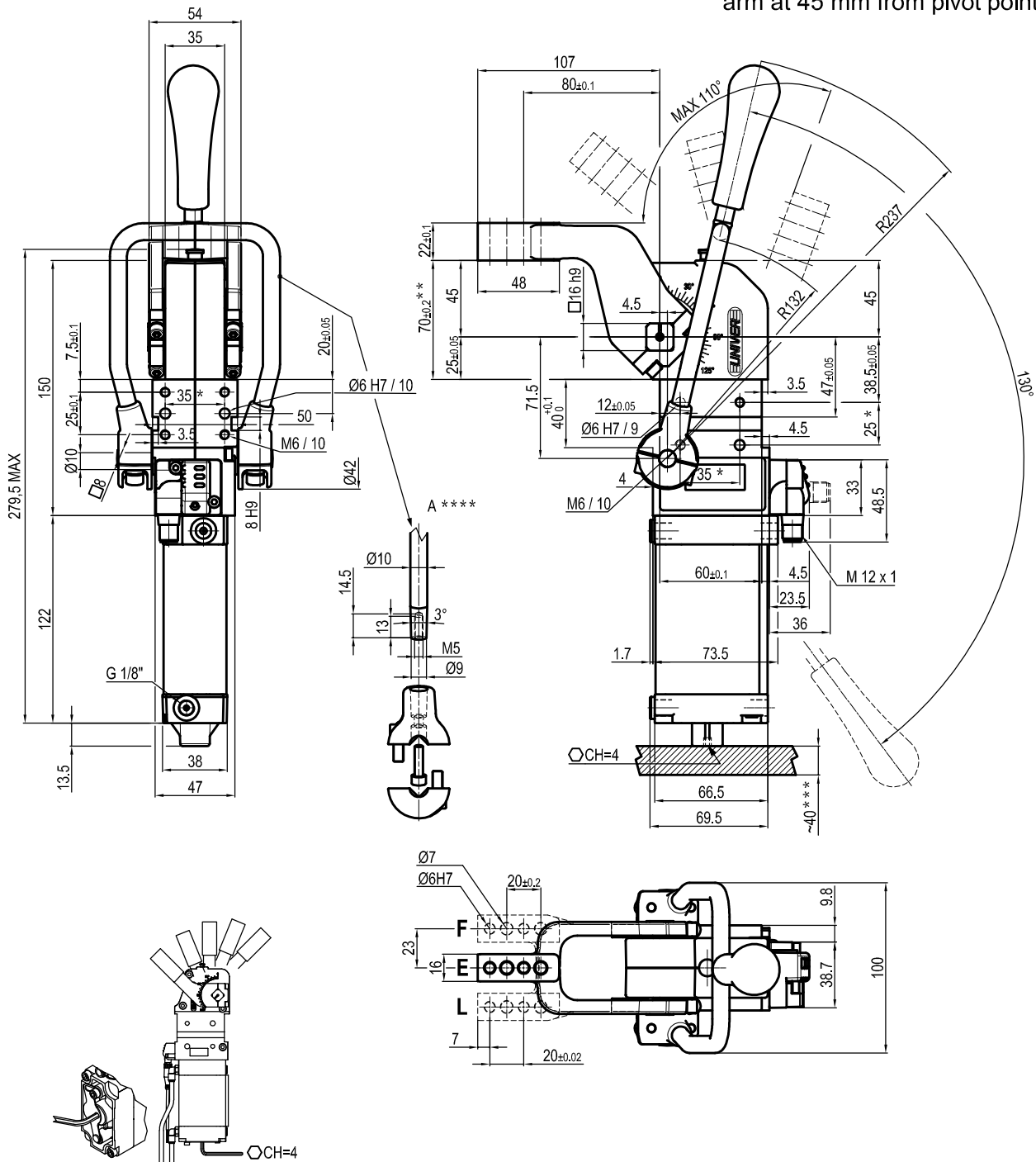

Bore Ø	Holding moment	Clamping moment (0.5 MPa)	Weight (Clamping arm not included)
40 mm	600 Nm	170 Nm	1.8 Kg

Min./Max. operating pressure: **0,4 / 0,6 MPa**
 Operating temperature: **5° + 45° C**
 Opening angle: **adjustable from 0° to 110°**
 Vertical arm mount position
 Electronic sensor with M12 swivel connector that can be orientated at 0° or 90°
 Supply voltage: 10÷30 Vdc
 IP code: **IP 65**
 Pneumatic ports on both sides

* : TOLERANCE BETWEEN DOWELS ± 0.02, TO SCREW HOLES ± 0.1
 ** : TOLERANCE AT 80 mm FROM PIVOT POINT
 *** : AREA TO ACCES ANGLE ADJUSTMENT

Subject to technical modification without notice.