

LCZ40

Irreversible pneumatic retractable locating pin unit, single rod



L	C	Z	4	0	0	4	0	E	A	E	R
1	2	3	4				5	6	7	8	

1 Series	2 Version	3 Size
-----------------	------------------	---------------

LC = Retractable locating pin unit

Z = Pneumatic-irreversible, single rod

40 = Ø 40 mm

4 Stroke	5 Sensor	6 Rod end style
-----------------	-----------------	------------------------

040 = 40 mm

N = No sensor (with protection plate)
E = Electronic sensor with M12 swivel connector

A = Rod for off-set pins
B = Rod with profiled end
C = Rod with cross-profiled end inner Ø 16 mm
D = Rod for off-set pins with oversized dowel holes

7 Rod orientation	8 Rod scraper
--------------------------	----------------------

E = East, standard



R = Metallic rod scraper

O = West



N = North



S = South



■ Only with A and D rod end style

UNIVERSAL Pneumatic retractable locating pin unit

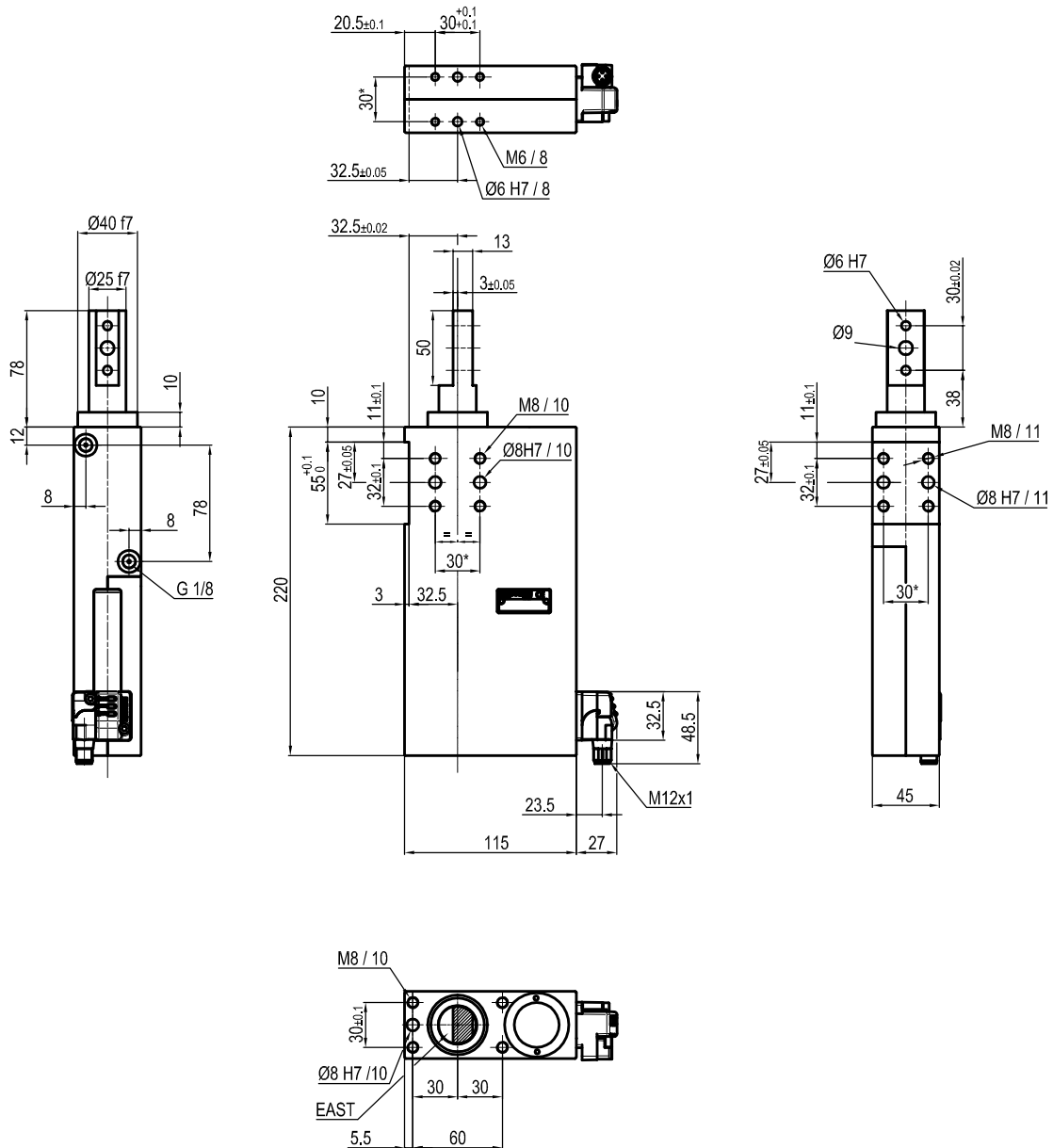

Bore Ø	Max. bending moment	Max. deflection moment	Weight
40 mm	6 Nm ±0.06°	7.5 Nm ±0.03	5.7 Kg

Min./max. operating pressure: **0,4 / 0,6 MPa**
 Operating temperature: **5° + 45° C**
 Strokes in mm.: **40**
 Electronic sensor with M12 swivel connector that can be orientated at 0° or 90°
 Supply voltage: 10+30 Vdc
 IP code: **IP 65**

* : TOLERANCE BETWEEN DOWEL HOLES ± 0.02, TO SCREW HOLES ± 0.1

Subject to technical modification without notice.

UNIVERSAL Pneumatic retractable locating pin unit

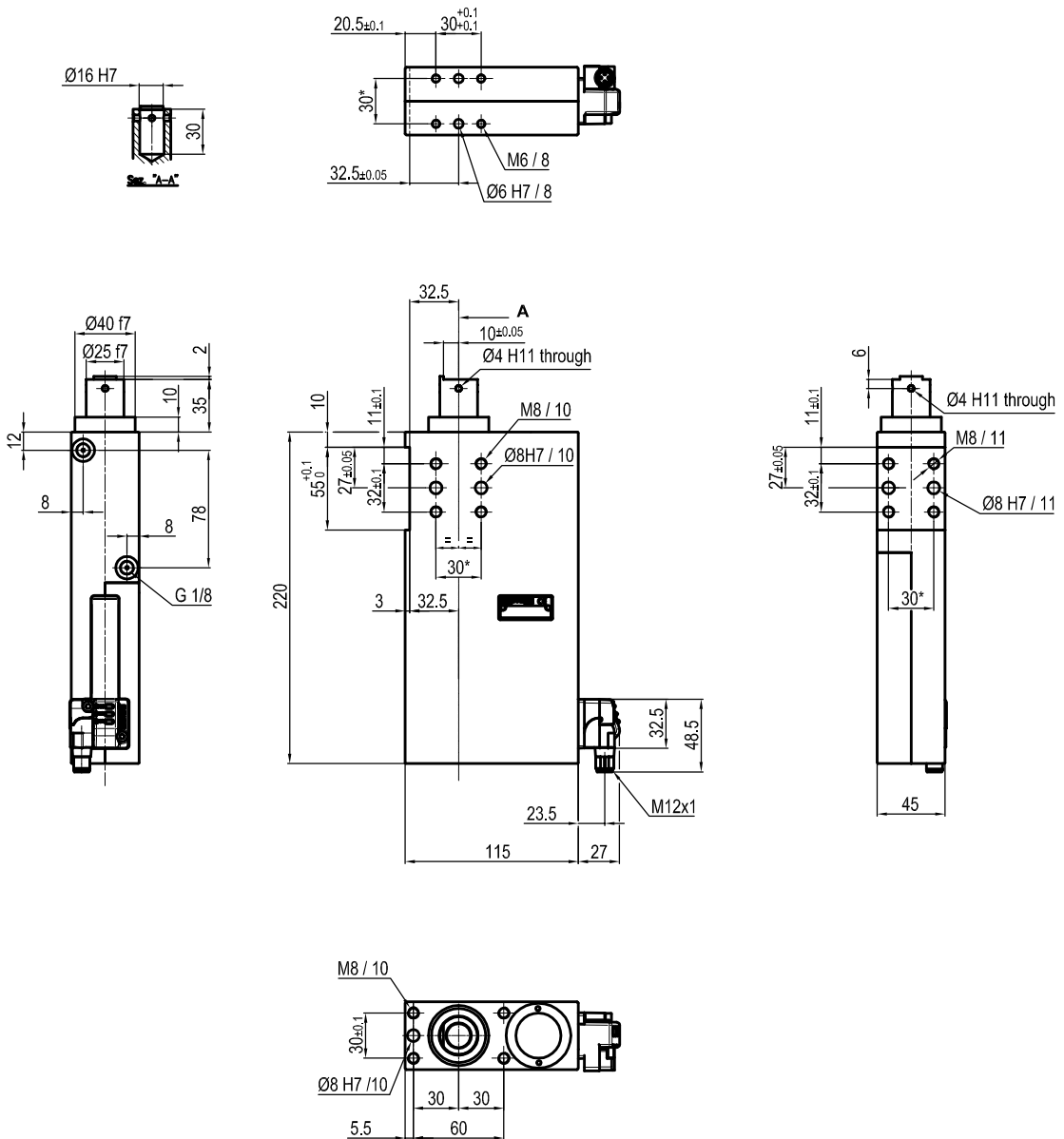

Bore Ø	Max. bending moment	Max. deflection moment	Weight
40 mm	6 Nm ±0.06°	7.5 Nm ±0.03	5.7 Kg

Min./max. operating pressure: **0,4 / 0,6 MPa**
 Operating temperature: **5° + 45° C**
 Strokes in mm.: **40**
 Electronic sensor with M12 swivel connector that can be orientated at 0° or 90°
 Supply voltage: 10+30 Vdc
 IP code: **IP 65**

* : TOLERANCE BETWEEN DOWEL HOLES ± 0.02, TO SCREW HOLES ± 0.1

Subject to technical modification without notice.

UNIVERSAL Pneumatic retractable locating pin unit

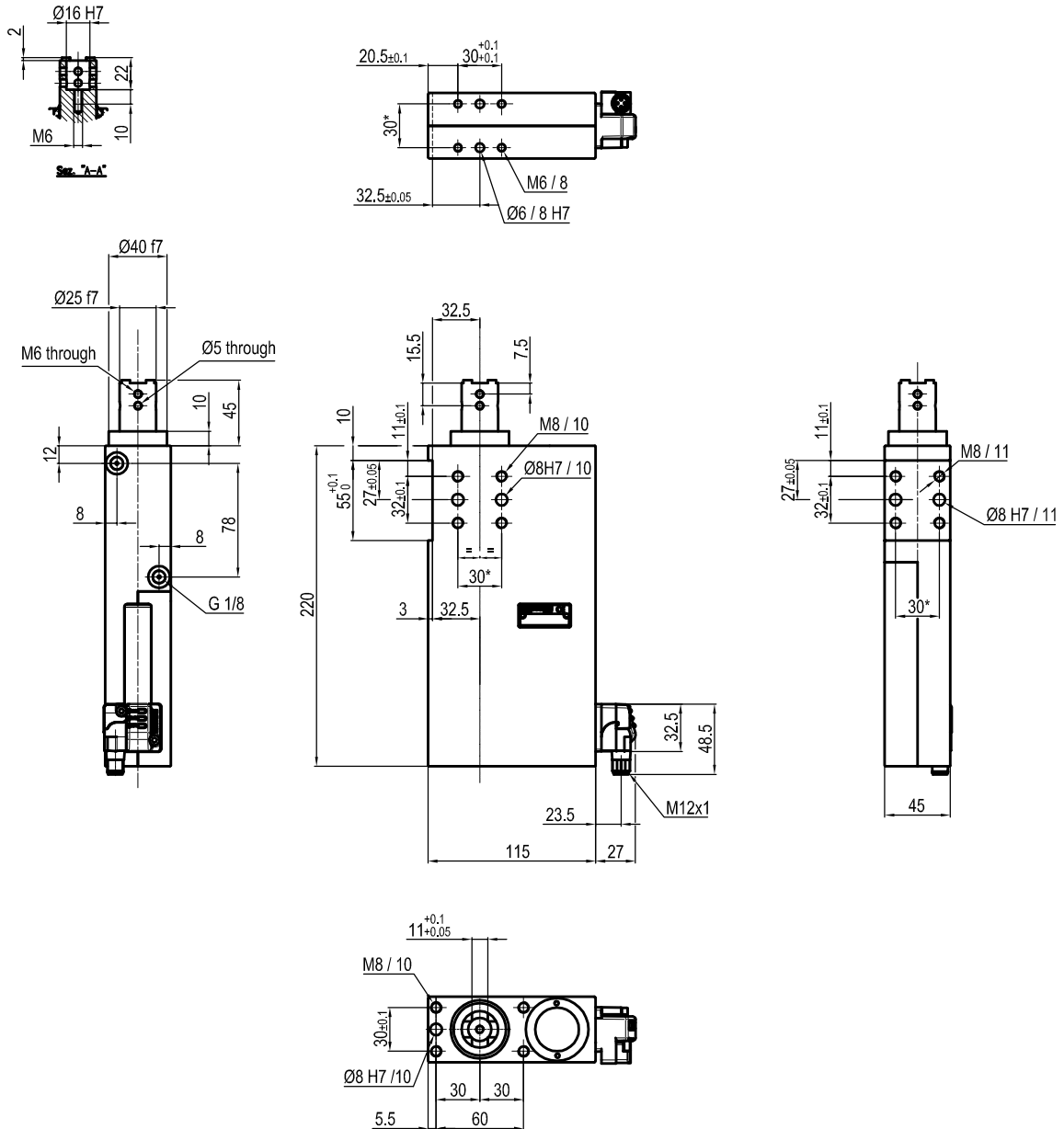

Bore Ø	Max. bending moment	Max. deflection moment	Weight
40 mm	6 Nm ±0.06°	7.5 Nm ±0.03	5.7 Kg

Min./max. operating pressure: **0,4 / 0,6 MPa**
 Operating temperature: **5° + 45° C**
 Strokes in mm.: **40**
 Electronic sensor with M12 swivel connector that can be orientated at 0° or 90°
 Supply voltage: 10+30 Vdc
 IP code: **IP 65**

* : TOLERANCE BETWEEN DOWEL HOLES ± 0.02, TO SCREW HOLES ± 0.1

Subject to technical modification without notice.

UNIVERSAL Pneumatic retractable locating pin unit

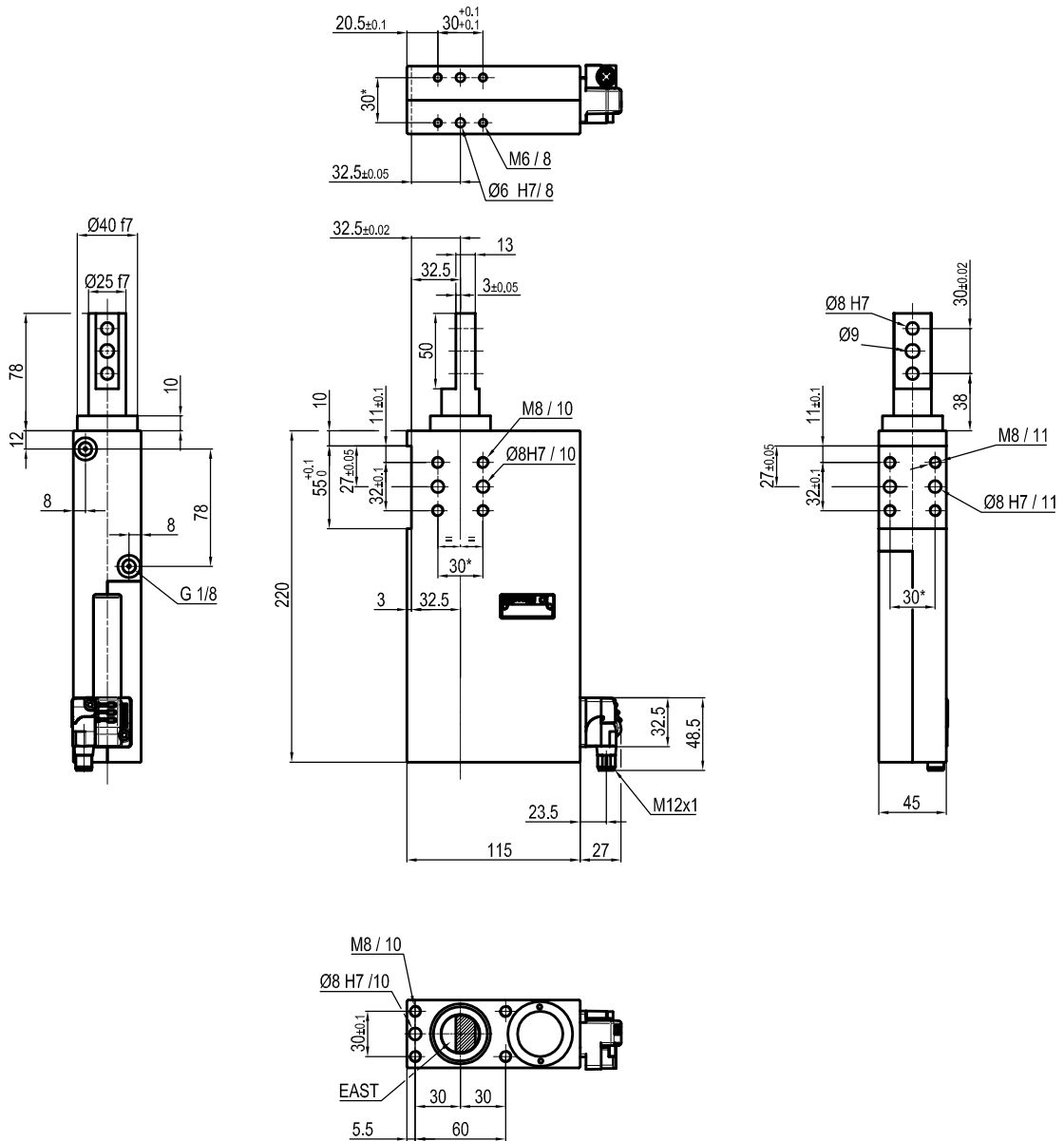

Bore Ø	Max. bending moment	Max. deflection moment	Weight
40 mm	6 Nm ±0.06°	7.5 Nm ±0.03	5.7 Kg

Min./max. operating pressure: **0,4 / 0,6 MPa**
 Operating temperature: **5° + 45° C**
 Strokes in mm.: **40**
 Electronic sensor with M12 swivel connector that can be orientated at 0° or 90°
 Supply voltage: 10+30 Vdc
 IP code: **IP 65**

* : TOLERANCE BETWEEN DOWEL HOLES ± 0.02, TO SCREW HOLES ± 0.1

Subject to technical modification without notice.