

# LCR63

Unità di centraggio pneumatica, testate compatte  
singola asta



L	C	R	6	3	0	5	0	E	A	E	R
1	2	3	4		5	6	7	8			

<b>1 Serie</b>	<b>2 Versione</b>	<b>3 Taglia</b>
----------------	-------------------	-----------------

LC = Unità di centraggio

R = Pneumatica, testate compatte,  
singola asta

63 = Ø 63 mm

<b>4 Corse</b>	<b>5 Sensore di posizione</b>	<b>6 Terminale asta</b>
----------------	-------------------------------	-------------------------

015 = 15 mm  
025 = 25 mm  
040 = 40 mm  
050 = 50 mm  
060 = 60 mm

N = Senza sensore  
(con piastra di chiusura)  
E = Sensore elettronico con connettore  
M12 orientabile

A = Asta per centraggi dislocati  
B = Asta con impronta a chiave  
C = Asta con impronta a chiave a croce,  
Ø interno 16 mm  
D = Asta per centraggi dislocati con fori spina  
maggiorati  
E = Asta con impronta chiave a croce,  
Ø interno 10 mm  
F = Asta con sede fissaggio laterale  
H = Asta con terminale piatto, Ø interno 10 mm  
I = Asta con terminale piatto, Ø interno 12 mm  
L = Asta con foro Ø 12 compatibile con  
CNOMO LCG  
M = Asta con foro Ø 20 compatibile con  
CNOMO LCG

<b>7 Orientamento asta</b>	<b>8 Raschiastelo</b>
----------------------------	-----------------------

E = Est, standard



O = Ovest



N = Nord



S = Sud



R = Raschiastelo metallico

■ Solo con terminale asta A o D

## UNIVERSAL Pneumatic retractable locating pin unit

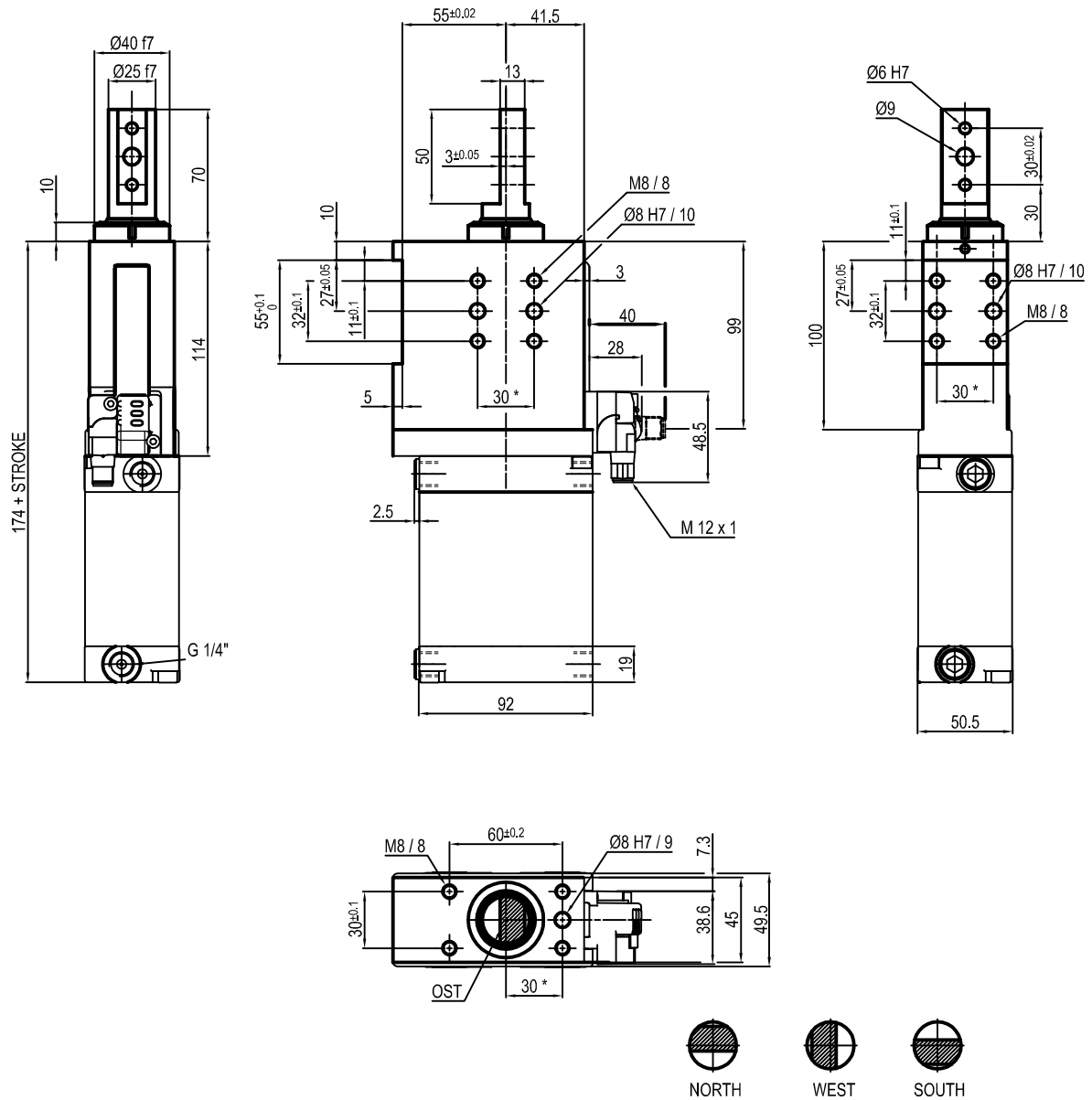

Bore Ø	Max. torque	Max. deflection moment	Weight
63 mm	6 Nm ±0.06°	7.5 Nm ±0.03°	3.4 Kg

Min./max. operating pressure: **0,4 / 0,6 MPa**  
 Operating temperature: **5° + 45° C**  
 Strokes in mm.: **15 - 25 - 40 - 50 - 60**  
 Electronic sensor with M12 swivel connector that can be orientated at 0° or 90°  
 Supply voltage: 10+30 Vdc  
 IP code: **IP 65**  
 Pneumatic ports on both sides

\* : TOLERANCE BETWEEN DOWEL HOLES ± 0.02, TO SCREW HOLES ± 0.1

Subject to technical modification without notice.

## UNIVERSAL Pneumatic retractable locating pin unit

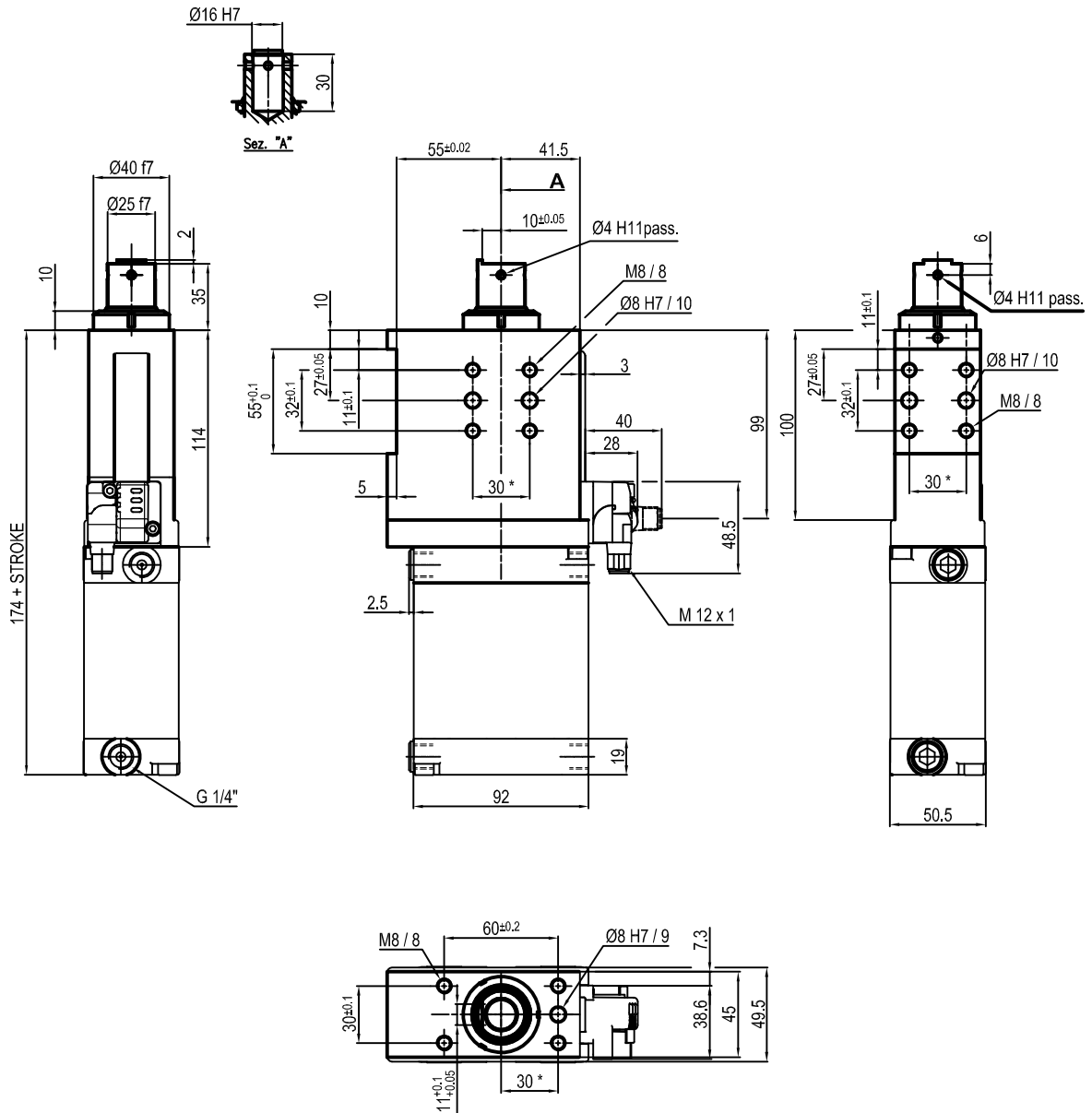

Bore Ø	Max. torque	Max. deflection moment	Weight
63 mm	6 Nm ±0.06°	7.5 Nm ±0.03°	3.4 Kg

Min./max. operating pressure: **0,4 / 0,6 MPa**  
 Operating temperature: **5° + 45° C**  
 Strokes in mm.: **15 - 25 - 40 - 50 - 60**  
 Electronic sensor with M12 swivel connector that can be orientated at 0° or 90°  
 Supply voltage: 10+30 Vdc  
 IP code: **IP 65**  
 Pneumatic ports on both sides

\* : TOLERANCE BETWEEN DOWEL HOLES ± 0.02, TO SCREW HOLES ± 0.1

Subject to technical modification without notice.

## UNIVERSAL Pneumatic retractable locating pin unit

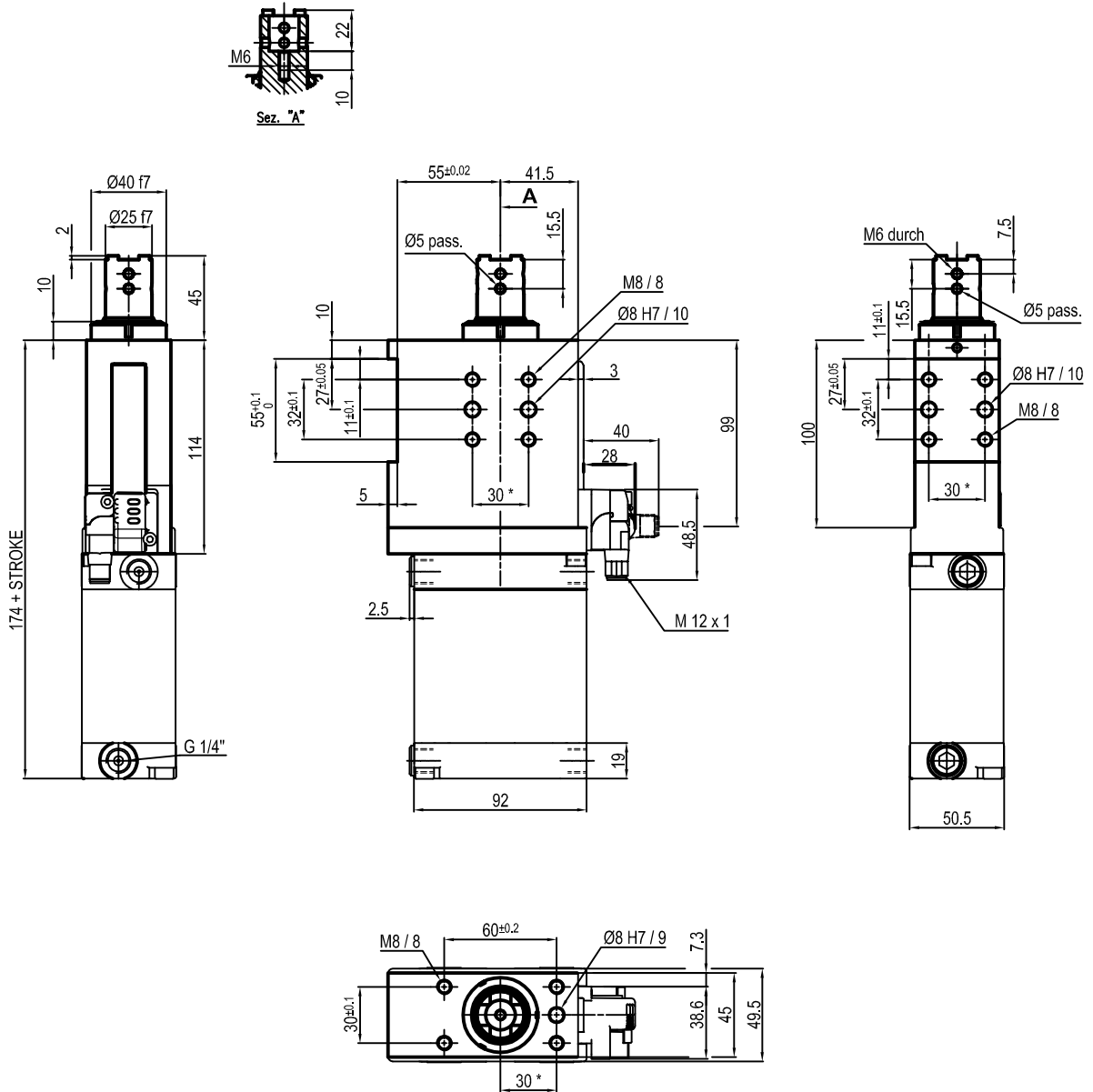

Bore Ø	Max. torque	Max. deflection moment	Weight
63 mm	6 Nm ±0.06°	7.5 Nm ±0.03°	3.4 Kg

Min./max. operating pressure: **0,4 / 0,6 MPa**  
 Operating temperature: **5° + 45° C**  
 Strokes in mm.: **15 - 25 - 40 - 50 - 60**  
 Electronic sensor with M12 swivel connector that can be orientated at 0° or 90°  
 Supply voltage: 10+30 Vdc  
 IP code: **IP 65**  
 Pneumatic ports on both sides

\* : TOLERANCE BETWEEN DOWEL HOLES ± 0.02, TO SCREW HOLES ± 0.1

Subject to technical modification without notice.

## UNIVERSAL Pneumatic retractable locating pin unit

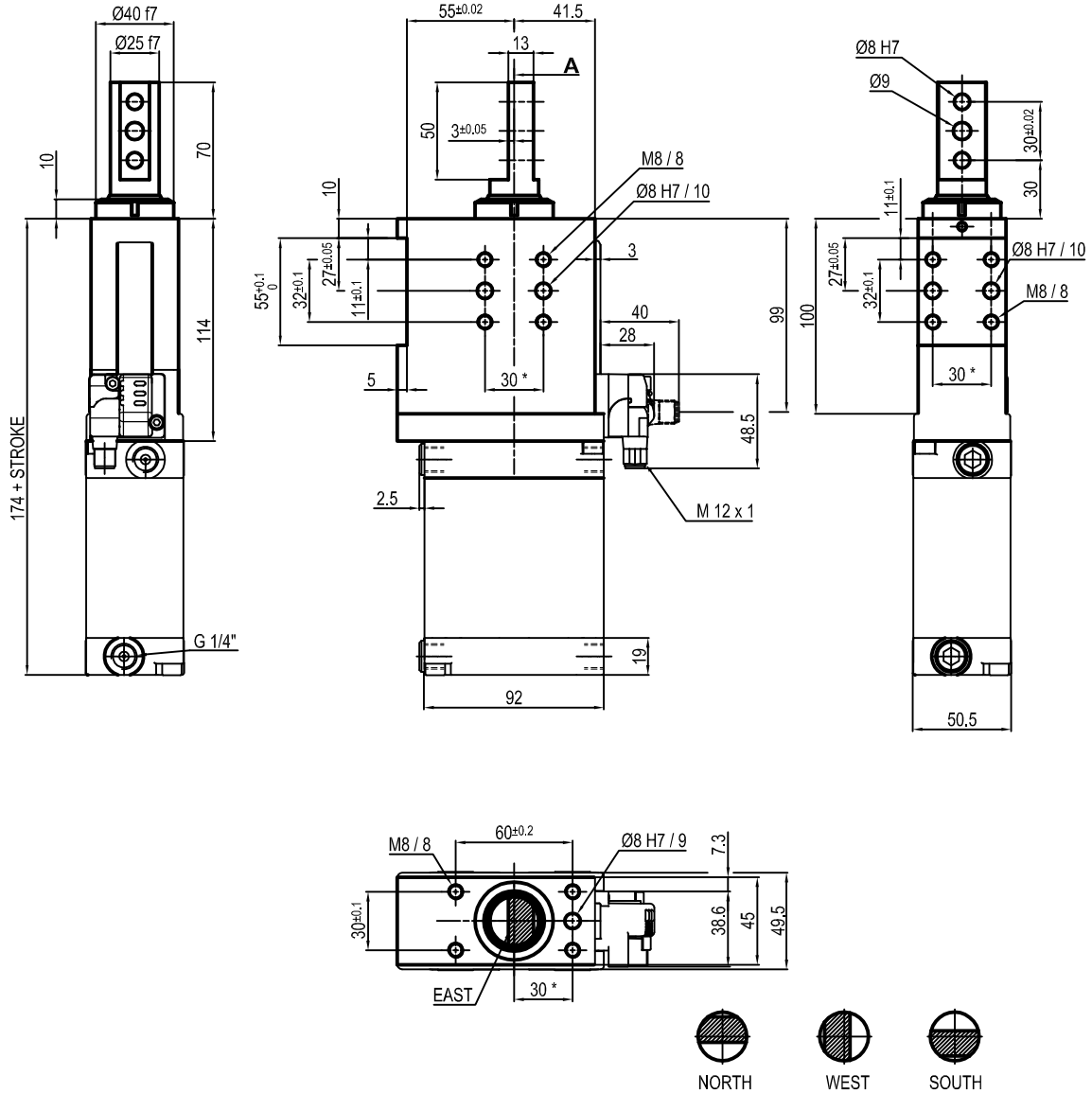

Bore Ø	Max. torque	Max. deflection moment	Weight
63 mm	6 Nm ±0.06°	7.5 Nm ±0.03°	3.4 Kg

Min./max. operating pressure: **0,4 / 0,6 MPa**  
 Operating temperature: **5° + 45° C**  
 Strokes in mm.: **15 - 25 - 40 - 50 - 60**  
 Electronic sensor with M12 swivel connector that can be orientated at 0° or 90°  
 Supply voltage: 10+30 Vdc  
 IP code: **IP 65**  
 Pneumatic ports on both sides

\* : TOLERANCE BETWEEN DOWEL HOLES ± 0.02, TO SCREW HOLES ± 0.1

Subject to technical modification without notice.

## UNIVERSAL Pneumatic retractable locating pin unit with rod's inner diameter $\varnothing 10$ mm

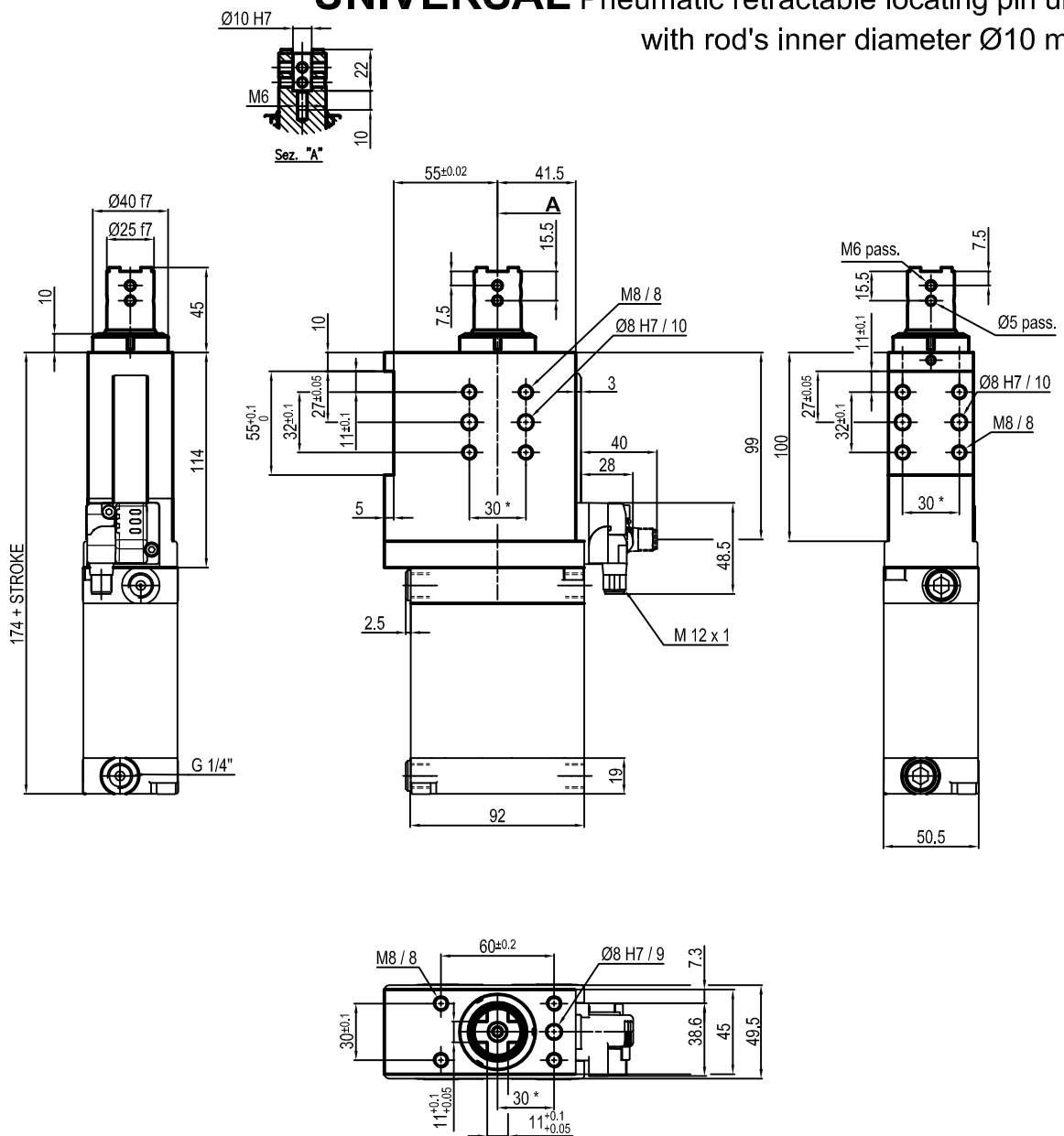

Bore $\varnothing$	Max. torque	Max. deflection moment	Weight
63 mm	6 Nm $\pm 0.06^\circ$	7.5 Nm $\pm 0.03^\circ$	3.4 Kg

Min./max. operating pressure: **0,4 / 0,6 MPa**  
 Operating temperature: **5° + 45° C**  
 Strokes in mm.: **15 - 25 - 40 - 50 - 60**  
 Electronic sensor with M12 swivel connector that can be orientated at 0° or 90°  
 Supply voltage: 10+30 Vdc  
 IP code: **IP 65**  
 Pneumatic ports on both sides

\* : TOLERANCE BETWEEN DOWEL HOLES  $\pm 0.02$ , TO SCREW HOLES  $\pm 0.1$

Subject to technical modification without notice.

## UNIVERSAL Pneumatic retractable locating pin unit

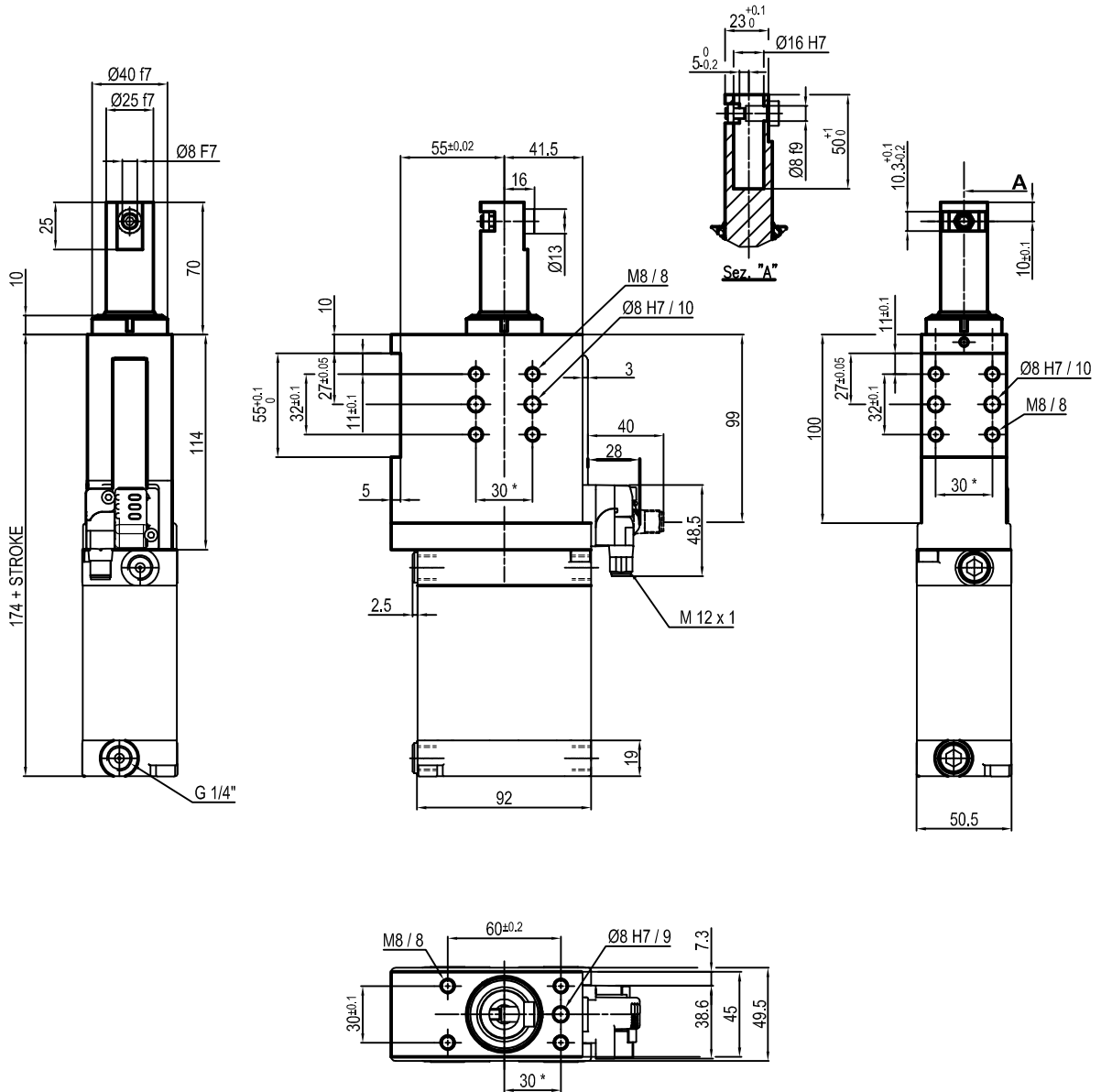

Bore Ø	Max. torque	Max. deflection moment	Weight
63 mm	6 Nm ±0.06°	7.5 Nm ±0.03°	3.4 Kg

Min./max. operating pressure: **0,4 / 0,6 MPa**  
 Operating temperature: **5° + 45° C**  
 Strokes in mm.: **15 - 25 - 40 - 50 - 60**  
 Electronic sensor with M12 swivel connector that can be orientated at 0° or 90°  
 Supply voltage: 10÷30 Vdc  
 IP code: **IP 65**  
 Pneumatic ports on both sides

\* : TOLERANCE BETWEEN DOWEL HOLES ± 0.02, TO SCREW HOLES ± 0.1

Subject to technical modification without notice.

## UNIVERSAL Pneumatic retractable locating pin unit with rod's inner diameter $\varnothing 10$ mm

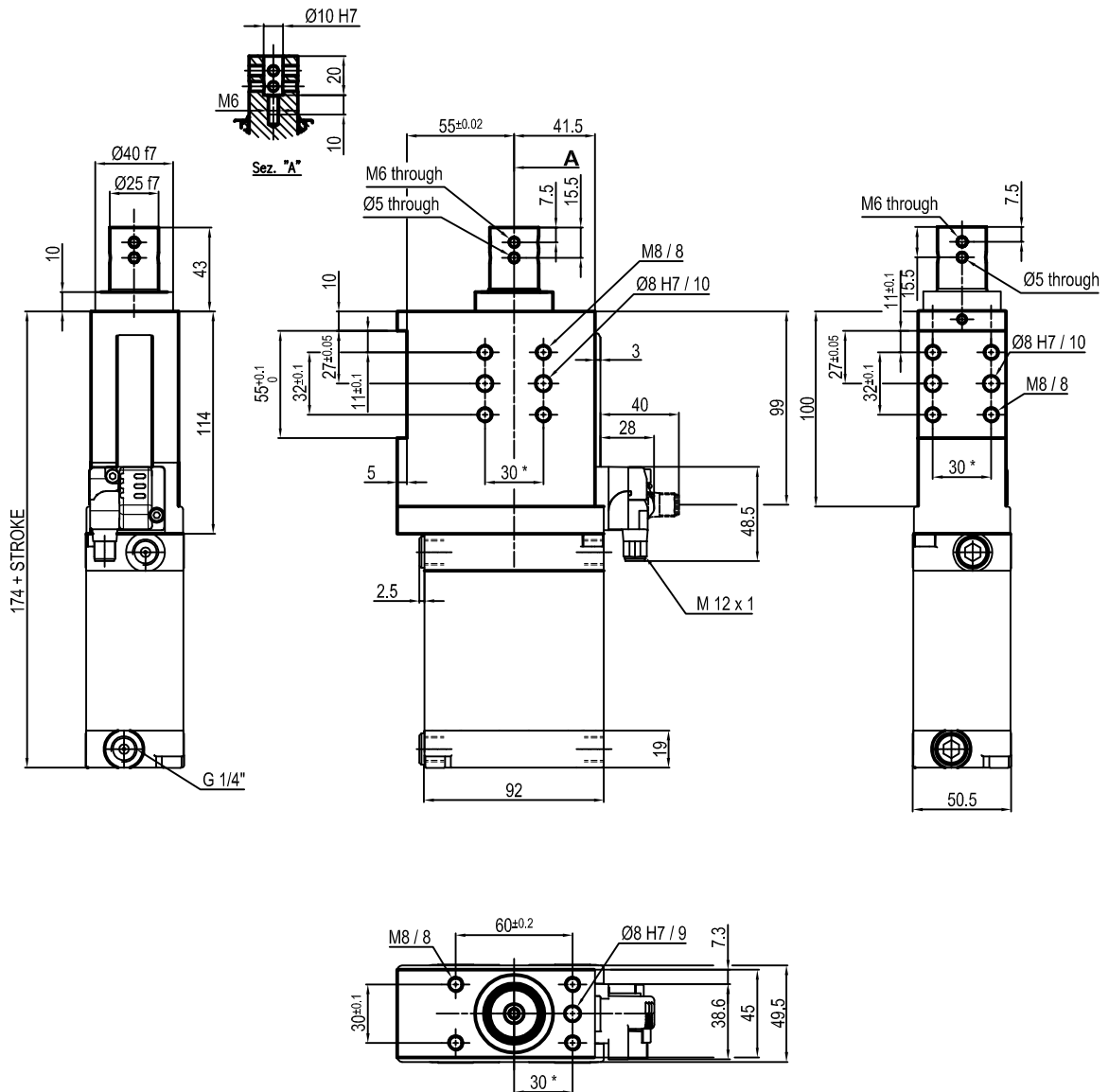

Bore $\varnothing$	Max. torque	Max. deflection moment	Weight
63 mm	6 Nm $\pm 0.06^\circ$	7.5 Nm $\pm 0.03^\circ$	3.4 Kg

Min./max. operating pressure: **0,4 / 0,6 MPa**  
 Operating temperature: **5° + 45° C**  
 Strokes in mm.: **15 - 25 - 40 - 50 - 60**  
 Electronic sensor with M12 swivel connector that can be orientated at 0° or 90°  
 Supply voltage: 10+30 Vdc  
 IP code: **IP 65**  
 Pneumatic ports on both sides

\* : TOLERANCE BETWEEN DOWEL HOLES  $\pm 0.02$ , TO SCREW HOLES  $\pm 0.1$

Subject to technical modification without notice.



## UNIVERSAL Pneumatic retractable locating pin unit with rod's inner diameter $\varnothing 10$ mm

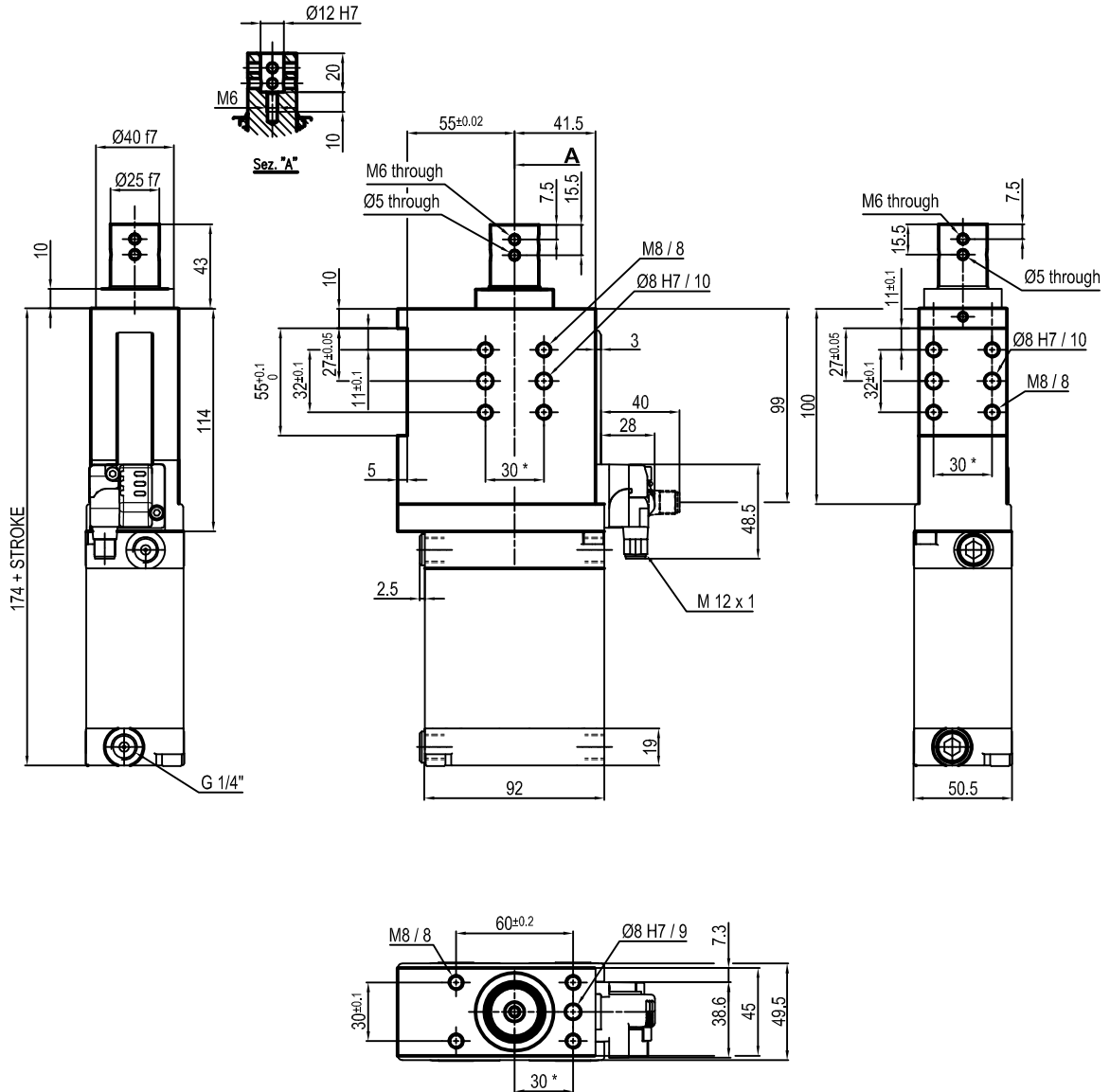

Bore $\varnothing$	Max. torque	Max. deflection moment	Weight
63 mm	6 Nm $\pm 0.06^\circ$	7.5 Nm $\pm 0.03^\circ$	3.4 Kg

Min./max. operating pressure: **0,4 / 0,6 MPa**  
 Operating temperature: **5° + 45° C**  
 Strokes in mm.: **15 - 25 - 40 - 50 - 60**  
 Electronic sensor with M12 swivel connector that can be orientated at 0° or 90°  
 Supply voltage: 10+30 Vdc  
 IP code: **IP 65**  
 Pneumatic ports on both sides

\* : TOLERANCE BETWEEN DOWEL HOLES  $\pm 0.02$ , TO SCREW HOLES  $\pm 0.1$

Subject to technical modification without notice.

## UNIVERSAL Pneumatic retractable locating pin unit

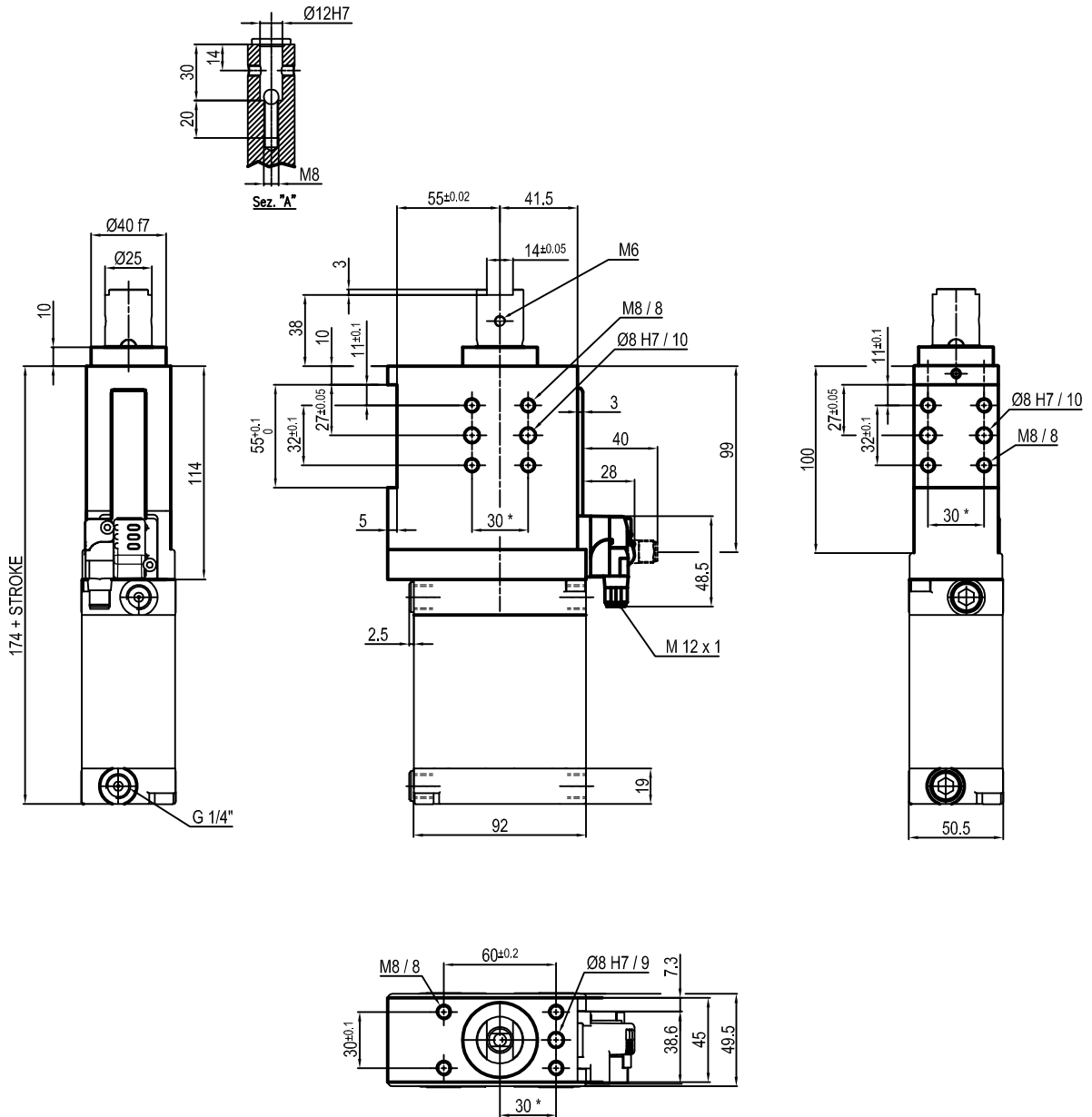

Bore Ø	Max. torque	Max. deflection moment	Weight
63 mm	6 Nm ±0.06°	7.5 Nm ±0.03°	3.4 Kg

Min./max. operating pressure: **0,4 / 0,6 MPa**  
 Operating temperature: **5° + 45° C**  
 Strokes in mm.: 25 - 50  
 Electronic sensor with M12 swivel connector that can be orientated at 0° or 90°  
 Supply voltage: 10÷30 Vdc  
 IP code: **IP 65**  
 Pneumatic ports on both sides

\* : TOLERANCE BETWEEN DOWEL HOLES ± 0.02, TO SCREW HOLES ± 0.1

Subject to technical modification without notice.

## UNIVERSAL Pneumatic retractable locating pin unit

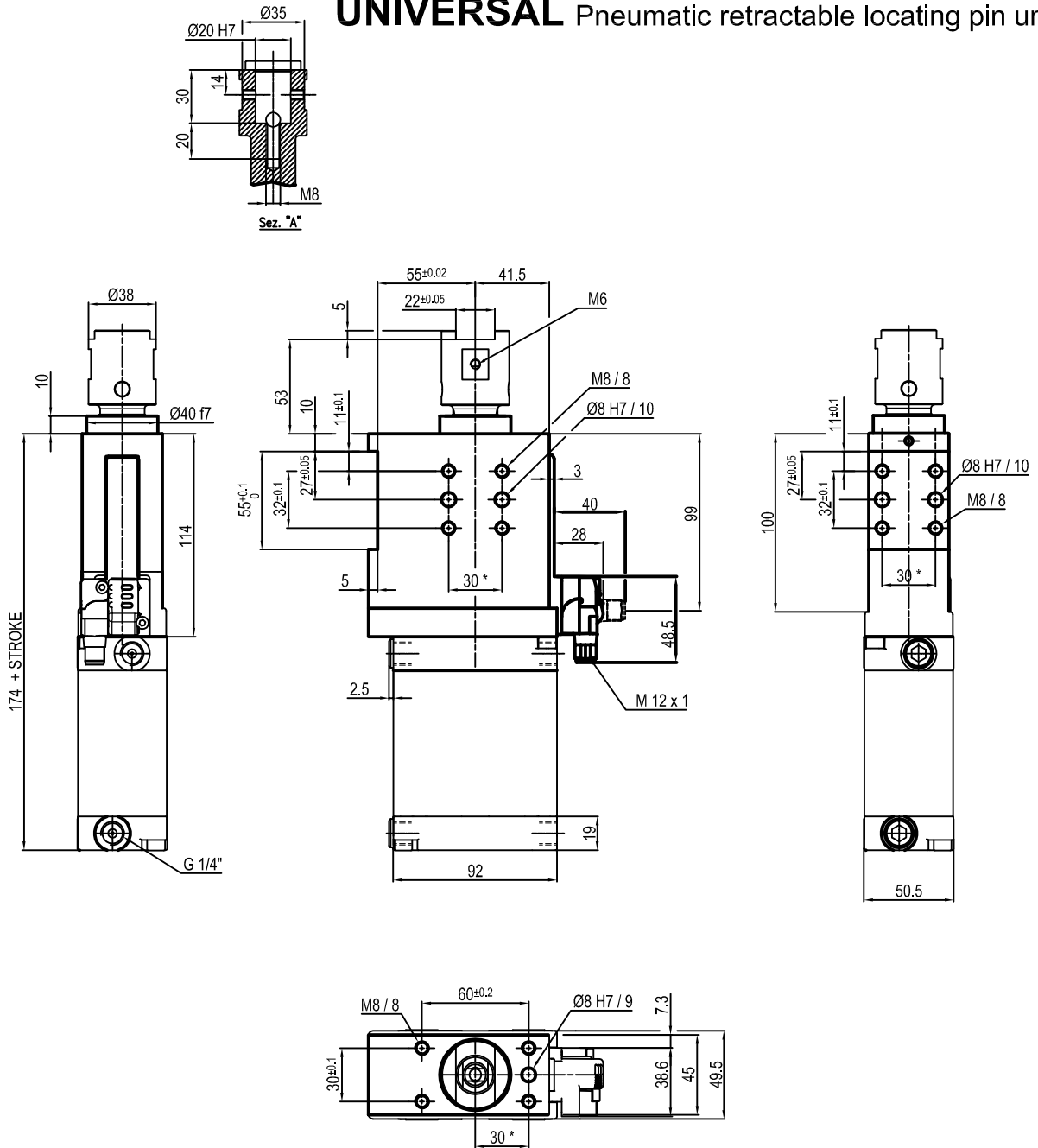

Bore Ø	Max. torque	Max. deflection moment	Weight
63 mm	6 Nm ±0.06°	7.5 Nm ±0.03°	3.4 Kg

Min./max. operating pressure: **0,4 / 0,6 MPa**  
 Operating temperature: **5° + 45° C**  
 Strokes in mm.: 25 - 50  
 Electronic sensor with M12 swivel connector that can be orientated at 0° or 90°  
 Supply voltage: 10+30 Vdc  
 IP code: **IP 65**  
 Pneumatic ports on both sides

\* : TOLERANCE BETWEEN DOWEL HOLES ± 0.02, TO SCREW HOLES ± 0.1

Subject to technical modification without notice.